

USB Function IP Core

*Author: Rudolf Usselman
rudi@asics.ws*

Rev. 1.3
May 30, 2001

1

Revision History

Rev.	Date	Author	Description
0.1	6/1/01	Rudolf Usselmann	First Draft
0.4	10/1/01	RU	Dropped the linked list for endpoints idea, removed the buffer. shared bit, added and modified registers. Added Appendix B: Configuring the Core.
0.5	11/1/01	RU	Changed buffer memory to a dual ported SSRAM. Added quadruple buffering. Filled in CSR register. Added size field to end point buffers.
0.6	13/1/01	RU	Added Change bars. Changed buffer memory back to single port SSRAM. Removed quadruple buffering (back to double buffering). Enhanced the way buffers work, added description. Added data organization section. Added various references to latency and bandwidth requirements. Added USB core behavior section.
0.7	15/1/01	RU	Added frame number and time (FRM_NAT) register. Filled in USB core behavior section. Filled in most of the flowcharts. Fixed endpoint interrupt register. Added suspend output to wishbone IF. Added names to some of the bits in the endpoint registers.
0.8	20/1/01	RU	Changed document format to double sided. Added Suspend and Resume Interrupts. Added RX control of packet that are not MAX_PL_SZ. Added vendor control IO port register and IOs. Added Setup description.
0.9	31/1/01	RU	Added DMA operations and signals. Added separate core selects for registers and buffer memory.
0.9b	20/2/01	RU	Some minor typing fixes. Added a brief discussion about PID sequencing. Modified the interrupts. Modified the WISHBONE interface.
1.0	28/2/01	RU	Added Buffer Overflow & Underflow descriptions. Changed clock domain separation (Figure 1). Removed document status "Preliminary Draft".
1.1	7/3/01	RU	Added USB device control flow charts. Gave Names to Endpoint Registers. Added Interrupt Section. Added Suspend & Resume Section. Added Appendix C: USB Core Structure. Made various grammar and syntax corrections.

Rev.	Date	Author	Description
1.2	30/3/01	RU	Rearranged Appendixes. Moved Buffer Memory (SSRAM) outside the core. Added Appendix describing SSRAM timing. Filled in Core Configuration Appendix. Modified DMA Operations section. Added OTS_STOP bit in endpoint CSR register. Added "OUT is smaller than MAX_PL_SZ" interrupt. Fixed addresses of registers.
1.3	30/5/01	RU	Fixed many syntax and grammar errors. Removed Software model Section. Added Appendix E: Software model, provided by Chris Ziomkowski (chris@asics.ws).

1

Introduction

The Universal Serial Bus (USB) has evolved to the standard interconnect between computers and peripherals. Everything from a mouse to a camera can be connected via USB. With the new USB 2.0 specification, data rates of over 480 Mb/s are possible.

The Universal Serial Bus is a point to point interface. Multiple peripherals are attached through a HUB to the host.

This core provides a function (peripheral device) interface. It can be used to interface almost any peripheral to a computer via USB. This core fully complies to the USB 2.0 specification and can operate at USB Full and High Speed rates (12 and 480 Mb/s).

Note:

This specification assumes that the core will most likely be used in a high speed environment and includes references to special high speed extensions. However, when operation in full speed mode only, some of those high speed extensions will not be used and the core will properly behave as a full speed function only.

(This page intentionally left blank)

2

Architecture

The figure below illustrates the overall architecture of the core. The host interface provides a bridge between the internal data memory and control registers to the function controller. The data memory and control registers interface to the Protocol Layer (PL). The protocol layer interfaces to UTMI interface block. The UTMI block interfaces to the PHY. Each of the blocks is described in detail below.

Figure 1: Core Architecture Overview

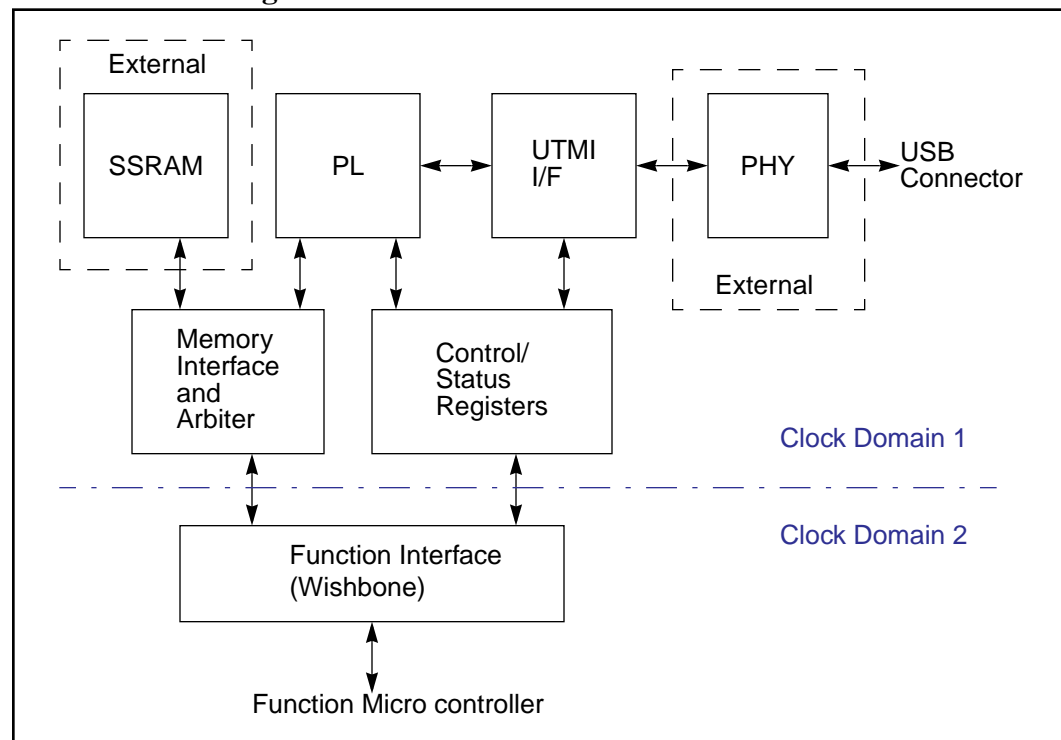

2.1. Clocks

The USB core has two clock domains. The UTMI interface block, runs off the clock provided by the PHY. The maximum clock output from the PHY is 60 MHz. The actual clock frequency depends on the operation mode (High Speed/Full

Speed). The UTMI block includes synchronization logic to the rest of the USB core.

All other blocks run off the clock from the host interface. Because of USB latency requirements, the host interface must run at least at 60 MHz. The goal is that the minimum frequency of the USB core host interface is at least 100Mhz.

2.2. Host Interface

The host interface block provides a consistent core interface between the internal functions of the core and the function-specific host or micro controller. The host interface is WISHBONE SoC bus specification Rev. B compliant.



2.2.1. Bandwidth Requirement

The USB maximum theoretical throughput is 480Mb/s, which translates to 60 Mbytes/s. On a 32 bit bus, four bytes (one word) are transferred per cycle. The minimum bandwidth requirement for the host is therefore 15 Mwords/s.

2.3. Memory Interface and Arbiter

The memory interface and arbiter arbitrates between the USB core and host interface for memory access. This block allows the usage of standard single port Synchronous SRAM. Besides arbitration it performs data steering and flow control.

2.4. SSRAM

The SSRAM is a single ported Synchronous SRAM block that is used to buffer the input and output data.

2.5. Protocol Layer (PL)

The protocol layer is responsible for all USB data IO and control communications.

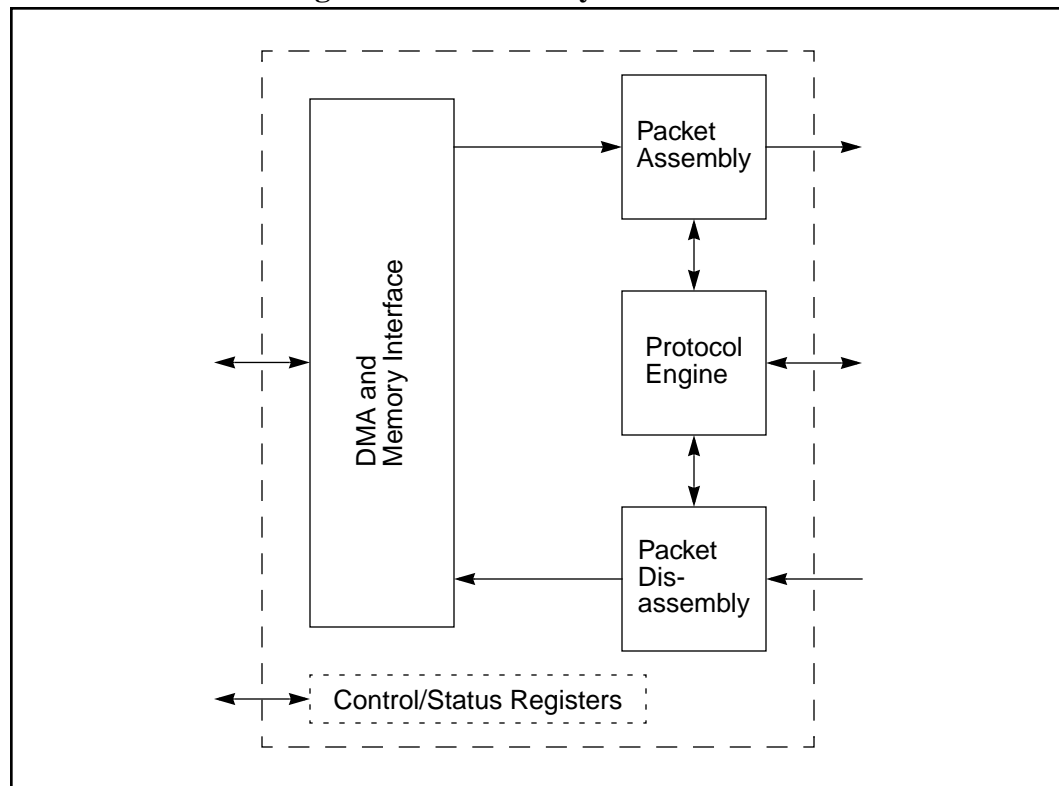
Figure 2: Protocol Layer Block

2.5.1. DMA & Memory Interface

This block interfaces to the data memory. It provides random memory access and also DMA block transfers.

2.5.2. Protocol Engine

This block handles all the standard USB protocol handshakes and control correspondence. Those are SOF tokens, acknowledgment of data transfers (ACK, NACK, NYET), replying to PING tokens.

2.5.3. Packet Assembly

This block assembles packets and places them in to the output FIFO.

2.5.4. Packet Disassembly

This block decodes all incoming packets and forwards the decoded data to the appropriate blocks.

2.6. UTMI I/F

This is the interface block to the UTMI compliant PHY (transceiver).

Figure 3: UTMI Interface Block

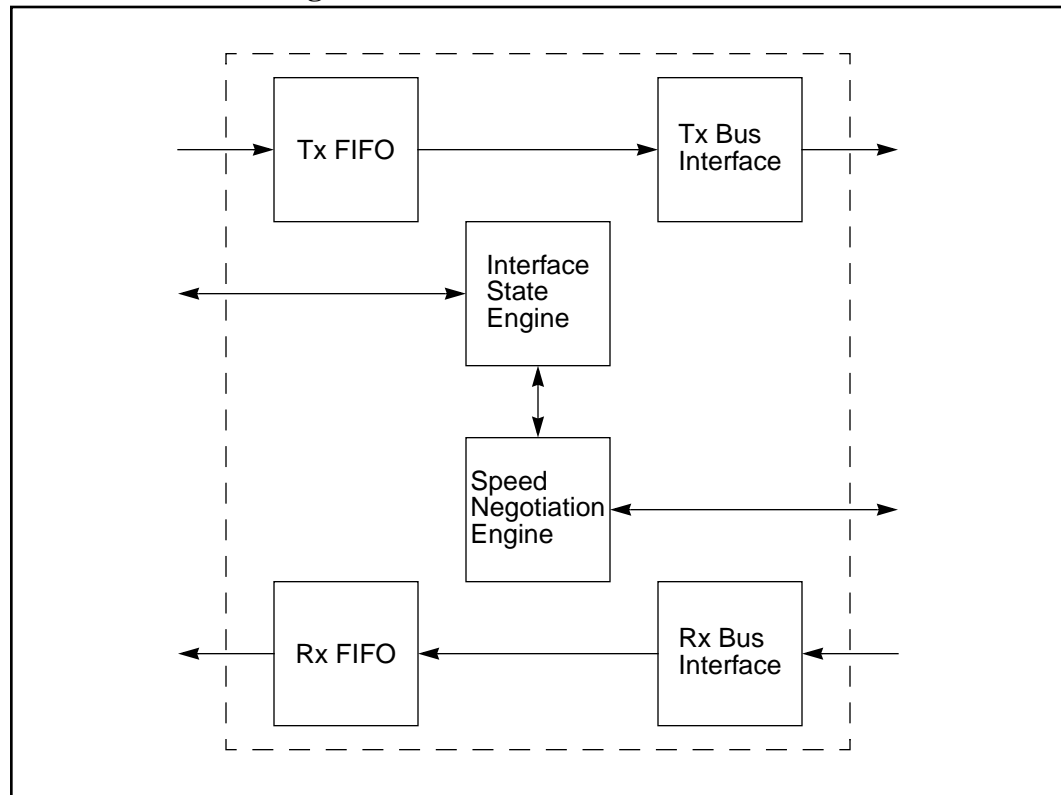

2.6.1. Interface State Engine

This block handles the interface state. It controls suspend/resume modes and Full Speed/High Speed switching.

2.6.2. Speed Negotiation Engine

This block negotiates the speed of the USB interface and handles suspend and reset detection.

2.6.3. Rx & Tx FIFOs

The FIFOs hold the temporary receive and transmit data.

2.6.4. Rx & Tx Bus Interface

These blocks ensure proper handshaking with the receive and transmit interfaces of the PHY.

3

Operation

This section describes the operation of the USB function controller. It first discusses the logical interface to the host micro controller (function) and then the logical USB interface.

The USB core uses a local buffer memory which is used as a temporary data storage. The memory size is user definable. Each endpoint has its own dedicated input/output buffer. No software intervention is needed between different endpoint accesses. Double buffers may be set up, reducing the latency requirement on the software, and increasing USB throughput.

Figure 4: Logical Representation of USB

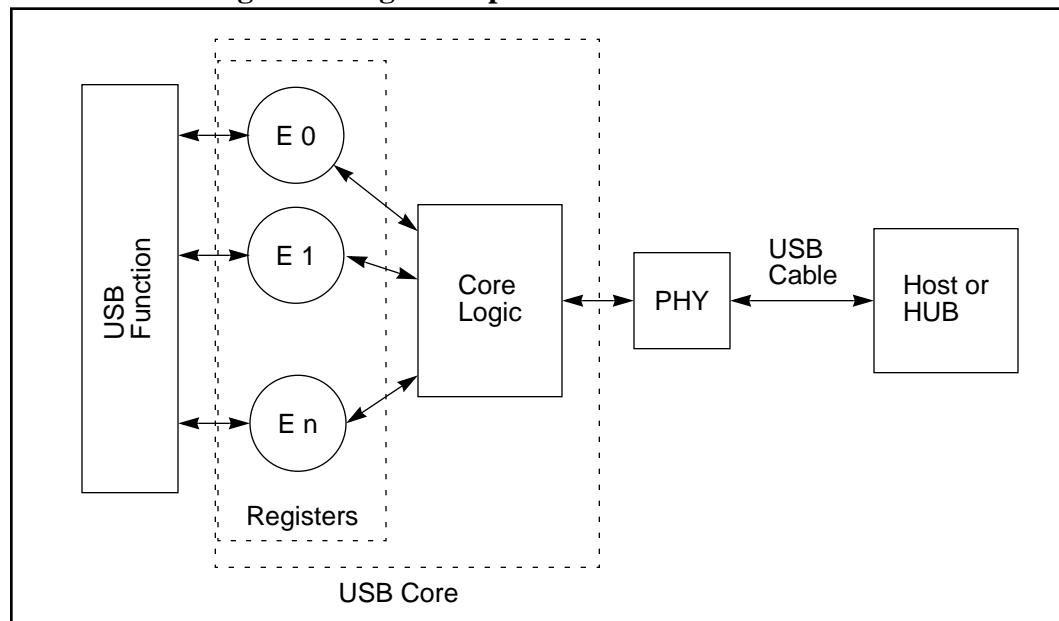

3.1. Endpoints

This USB core supports up to 16 endpoints. The actual number of endpoints is set before synthesizing the core.

The function controller must set up the endpoints by writing to the endpoint registers: EPn_CSR, EPn_INT, EPn_BUFx.

The function controller must also assign actual endpoint numbers to each endpoint (EP_NO). The endpoint numbering in this specification refers to the physical endpoints. The actual logical (the one that is matched against the endpoint field in tokens from the host) must be set in the EPn_CSR register EP_NO field. The software must make sure that all endpoints for a given transaction type are unique.

3.1.1. Buffer Pointers

The buffer pointers point to the input/output data structure in memory. A value of all ones (7FFFh) indicates that the buffer has not been allocated. If all buffers are not allocated, the core will respond with NAK acknowledgments to the USB host.

This USB core supports a double buffering feature which reduces the latency requirements on the functions micro controller and driver software. Double buffering is enabled when all buffer pointers have been set. Data is being retrieved/filled from/to the buffers in a round robin fashion. When data is sent to/from an endpoint, first buffer 0 is used. When the first buffer is empty/full, the function controller may be notified via an interrupt. The function controller can refill/empty buffer 0 now. The USB core will now use buffer 1 for the next operation. When the second buffer is full/empty, the function controller is interrupted, and the USB core will use buffer 0 again, and so on. Any buffer that is not allocated will be skipped. A buffer that has the used bit set will cause the core to stall, replying with NAK/NYET acknowledgments to the host.

The Buffer Used bits indicate when a buffer has been used (this information is also provided in the Interrupt Source register). The function controller must clear these bits after it has emptied/refilled the buffer.

A buffer may be larger than the maximum payload size. In that case, multiple packets will be sourced/placed from/to a buffer. A buffer for an OUT endpoint must always be in multiples of maximum payload size. When the remaining space in a buffer is less than the maximum payload size (because a one or more packets with less than maximum payload were received), the buffer is considered full, and the USB core will switch to the next buffer. For example, if the maximum payload size is 512 bytes, the buffer may be 512, 1024, 1536, 2048, etc. bytes large. The software should always check the buffer size field. It should be zero when the entire buffer has been used. If the buffer size is not zero, then the size field indicates how many bytes of the buffer have not been used. There is no such limitation for IN buffers. The core will always transmit the maximum possible number of bytes. The maximum possible number of bytes is always the smaller one of maximum payload size and remaining buffer size.

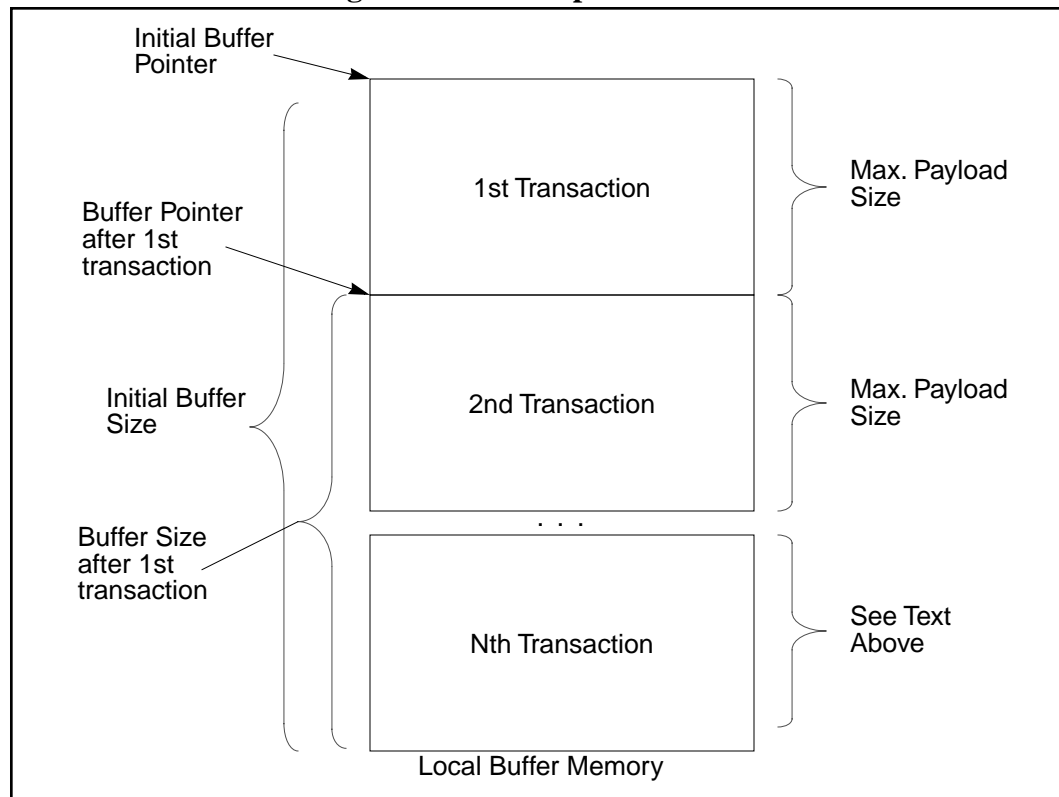
Figure 5: Buffer Operation

Control endpoints are somewhat special because they can receive and transmit data. Therefore, for control endpoints, Buffer 0 is always an OUT buffer, and Buffer 1 always an IN buffer. Data from SETUP and OUT tokens will therefore always be written to Buffer 0. Data sent in response to an IN token is always retrieved from Buffer 1.

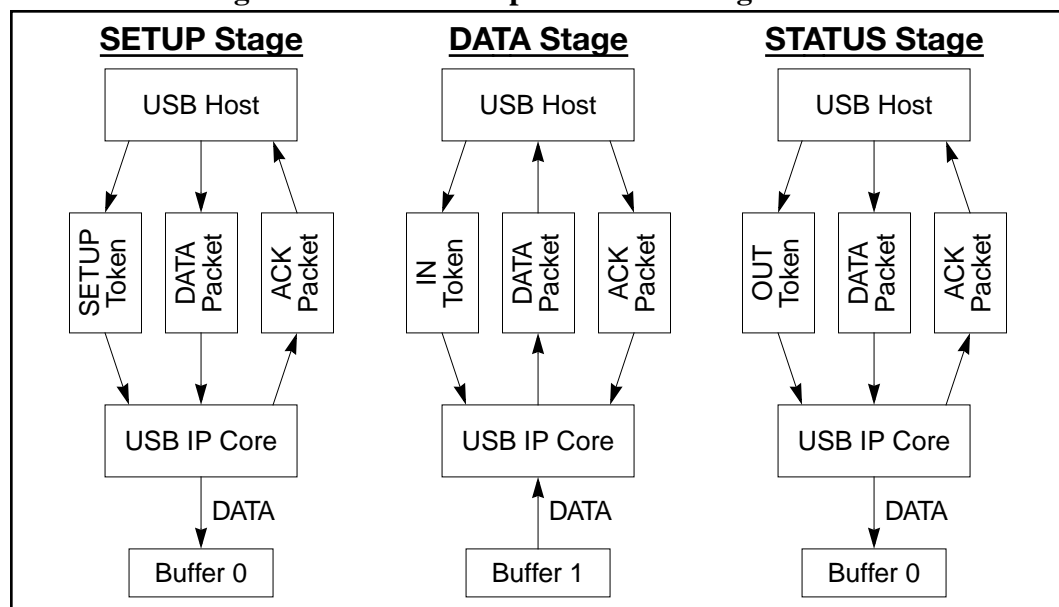
Figure 6: Control Endpoint Buffer Usage

3.1.2. Buffer Underflow

A buffer underflow condition occurs when either the function controller or external DMA engine did not fill the internal buffer with enough data for one MAX_PL_SZ packet. When an IN token is received in this condition, the USB core will reply with a NACK to the host. No special handling is required by the function controller. The UCB core will continue sending a NACK to each IN token, as long as this condition is true.

When both buffers are not allocated or empty (USED bit set), a buffer underflow condition occurs as well.

3.1.3. Buffer Overflow

A buffer overflow occurs when a packet has been received that does not fit into the buffer. The packet will be discarded and a NACK will be sent to the host.

Typically the buffer would be set up to hold one or more MAX_PL_SZ packets. There is no guarantee that the host will actually send MAX_PL_SZ packets, and therefore the buffer will not be completely filled with MAX_PL_SZ data on each transfer.

When a buffer overflow occurs, the USB core will discard the received data and reply with a NACK to the host. It will continue discarding received data and replying with NACK to each OUT token which payload size does not fit into the buffer.

When both buffers are not allocated or full, the USB core will immediately reply with a NACK when it receives an OUT token (it will not wait for the actual data packet from the host).

3.1.4. Data Organization

Since the buffer memory is 32 bits wide and USB defines all transactions on byte boundaries it is important to understand the relationship of data in the buffer to actual USB byte sequence. This USB core supports Little Endian byte ordering.

Figure 7: Byte Ordering

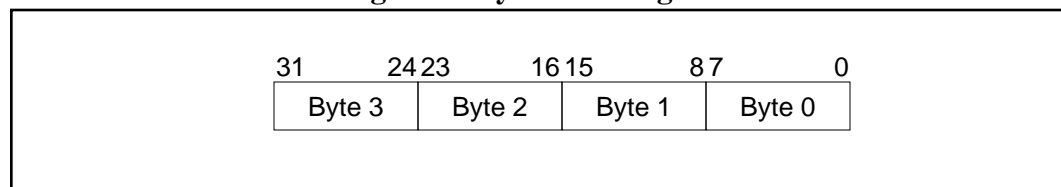

The buffer pointer always points to byte 0. The USB core always fetches four bytes from the buffer memory. The actual final byte that is transmitted in the Nth transaction depends on the Buffer Size. The MaxPacketSize must always be a multiple of 4 bytes.

3.2. DMA Operation

DMA operation allows completely transparent data movement between the USB core and the function attached to the WISHBONE bus. Once set up, no function micro controller intervention is needed for normal operations. Each endpoint has an associated pair of DMA_REQ and DMA_ACK signals.

When the DMAEN bit in the channel CSR register is set, the USB core will use the DMA_REQ and DMA_ACK signals for DMA flow control. The DMA_REQ signal is asserted when the buffer contains data or when the buffer is empty and needs to be filled. The DMA must reply with a DMA_ACK for each word (4 bytes) transferred. In DMA mode, the USED bits are not used and always cleared.

In DMA mode, only one buffer (buffer 0) is used. Buffer 1 is never used in DMA mode. Both buffer 0 and the external DMA must be set up to the same starting location in the USB memory buffer (the actual address for the external DMA will vary depending on the external address decoder for the USB core buffer select). They must also be set up to equal buffer size and wrap around when the amount of bytes specified has been transferred.

The buffer must hold at least one MAX_PL_SZ packet. Depending on DMA and external bus latency it may be set up to hold more than one packet.

MAX_PL_SZ must be set in 4 byte multiples, as the USB core does not support byte transfers. For OUT endpoints it is impossible to guarantee that a received packet will be in multiples of 4 bytes. The USB core provides a mechanism to recover in those cases: Whenever the received packet is smaller than MAX_PL_SZ, an interrupt may be generated to notify the function controller of this condition. In addition buffer1 is set to the local buffer address of the packet that was smaller than MAX_PL_SZ. The size field in buffer1 indicates the number of actual bytes in that packet. The USB core will always pad the buffer to MAX_PL_SZ bytes, so that DMA transfers can continue uninterrupted.

If the OTS_STOP bit is set in the endpoint CSR register, the endpoint will be disabled to allow the function controller enough time to deal with the short packet. The function controller must re-enable the endpoint by setting the EP_DIS field in the endpoint CSR register to Normal Operation.

3.3. PID Sequencing

USB utilizes PID sequencing to keep data transfers synchronized. It also provides a mechanism to recover data and synchronization when synchronization is lost. Synchronization can be lost due to corrupt packets, resulting in bad CRCs. This USB core fully implements and follows the PID synchronization and recovery as specified in the USB specification.

Isochronous endpoints provide no mechanism to automatically recover lost data due to a loss of synchronization. The USB core will automatically resynchronize with the host, however, since isochronous endpoints have no handshaking stage, have therefore no way to inform the host of such failures. The USB core provides a "PID Sequencing Error" interrupt for this cases in order for the function controller to be notified of such events. This interrupt will only be asserted for iso-

chronous OUT endpoints. For any other endpoints it has no meaning and is automatically disabled.

3.4. USB Core Memory Size

This USB core includes a memory block which it uses for storing data and endpoint control information. The memory is 32 bits wide. Depending on the application, the user should choose the appropriate memory size for the buffer memory.

Based on the actual number of endpoints and application, the memory can be as small as 256 bytes. The maximum supported memory size is 128 Kilobytes.

3.5. USB Core Behavior

Below table illustrates the behavior of the USB core. It also summarizes all “What if?” conditions. (This information is mostly copied from the USB 2.0 specification. Some items required interpretation of the information provided in the USB 2.0 specification).

Table 1: Core Specification and Behavior

Condition/ Operation	Full Speed Mode Behavior	High Speed Mode Behavior
Packet Sizes		
Isochronous Transfer Max. Payload size	1023 bytes	1024 bytes
Interrupt Transfer Max. Payload size	64 bytes	1024 bytes
Bulk Transfer Max. Payload size	8, 16, 32, 64 bytes	512 bytes
Timing		
One Bit Time	83.33nS	2.0833 nS
UTMI Clock (UCLK)	16.67 nS	16.67 nS
Max. Inter Packet Delay (measured on the USB bus)	7.5 Bit Times (~622 nS)	192 Bit Times (400 nS)
UTMI Rx worst case delay	17 UCLK (~283 nS)	63 Bit Times or 8 UCLK (~132 nS)
UTMI Tx worst case delay	5 UCLK (~83 nS)	16 Bit Times or 2 UCLK (~33 nS)
Worst Case USB core allowed decision time (Rx to Tx)	~256 nS (15 UCLK)	96 Bit Times or 12 UCLK (200 nS)
Worst Case USB core allowed decision time (Tx to Tx)	7.5 Bit Times or 37 UCLK (~622 nS)	192 Bit Times or 24 UCLK (400 nS)

Table 1: Core Specification and Behavior

Condition/ Operation	Full Speed Mode Behavior	High Speed Mode Behavior
Data PID sequencing		
Isochronous Transfer Data PID sequencing	Normal Endpoints use DATA0 only High Speed High Bandwidth Endpoints perform data PID sequencing depending on the number of transaction per microframe and data flow: IN Endpoints: 1 transaction (<1024 bytes each): DATA0 only 2 transaction (513-1024 bytes each): DATA1, DATA0 3 transaction (683-1024 bytes each): DATA2, DATA1, DATA0 OUT Endpoints: 1 transaction (<1024 bytes each): DATA0 only 2 transaction (513-1024 bytes each): MDATA, DATA1 3 transaction (683-1024 bytes each): MDATA, MDATA, DATA2	
Interrupt Transfer Data PID sequencing	DATA0/DATA1 toggle either continuously or on successful transactions.	
Bulk Transfer Data PID sequencing	DATA0/DATA1 toggle ONLY on successful transactions.	
Packet Errors and Mismatches		
Packet with Address Mismatch	Ignored, no action is taken.	
Endpoint Field mismatch	Ignored, no action is taken. (The function controller may be interrupted.)	
Packet with bad PID checksum received	Ignored, no action is taken. (The function controller may be interrupted.)	
Token with bad CRC5 received	Ignored, no action is taken. (The function controller may be interrupted.)	
Packet with bad CRC16	Ignored, no action is taken. (The function controller may be interrupted.)	
Unsupported token (e.g. OUT endpoint receives an IN token)	Ignored, no action is taken. (The function controller may be interrupted.)	
Tokens		
PRE and SPLIT tokens	Ignored, no action is taken.	
SOF Token	Frame number is recorded in the FRM_NAT register, if frame number is the same as previous, the same frame number field in the FRM_NAT register is increment. The frame time counter in the FRM_NAT register is reset.	
PING Token received and have space for MAX_PL_SZ	N/A (Ignored, no action is taken.)	Issue ACK handshake

Table 1: Core Specification and Behavior

Condition/ Operation	Full Speed Mode Behavior	High Speed Mode Behavior
PING Token received and no space for MAX_PL_SZ	N/A (Ignored, no action is taken.)	Issue NAK handshake.
PING Token received and HALT mode set	N/A (Ignored, no action is taken.)	Issue STALL handshake.
IN Endpoint		
IN Token received and HALT mode set	Issue STALL handshake.	
IN Token received both buffers either have the USED bit set are not allocated	Issue NAK handshake.	
IN Token received, can transmit data	Send data packet.	
Host sends ACK after receiving data packet	Transaction successful, go to IDLE state.	
No response from host - time-out (also corrupted response from host)	Do not advance PID toggle bits and buffer pointers. Go to IDL state. Host will retry IN token.	
OUT Endpoint		
OUT Token received and HALT bit is set	Issue STALL handshake.	
OUT Token received and PID sequence mismatch	Issue ACK (ignore data packet).	
OUT Token received both buffers have either the USED bit set or are not allocated	Issue NAK handshake (ignore data packet)	
OUT Token received can accept data	Issue ACK handshake.	
OUT Token received can accept this data and have room for one more MAX_PK_SZ		Issue ACK response.

Table 1: Core Specification and Behavior

Condition/ Operation	Full Speed Mode Behavior	High Speed Mode Behavior
OUT Token received, can accept this data and does not have room for one more MAX_PK_SZ		Issue NYET response.
Data packet CRC16 error or received next token	Ignore, no acknowledgment, handle new token.	
Control Endpoint		
SETUP Stage	Same as OUT Token Above	
DATA Stage	Same as IN Token above	
STATUS Stage	Same as OUT Token Above	

3.6. USB Core Flowcharts

Below flowcharts outline the basic operation of the USB core.

Figure 8: USB Core Main Flowchart

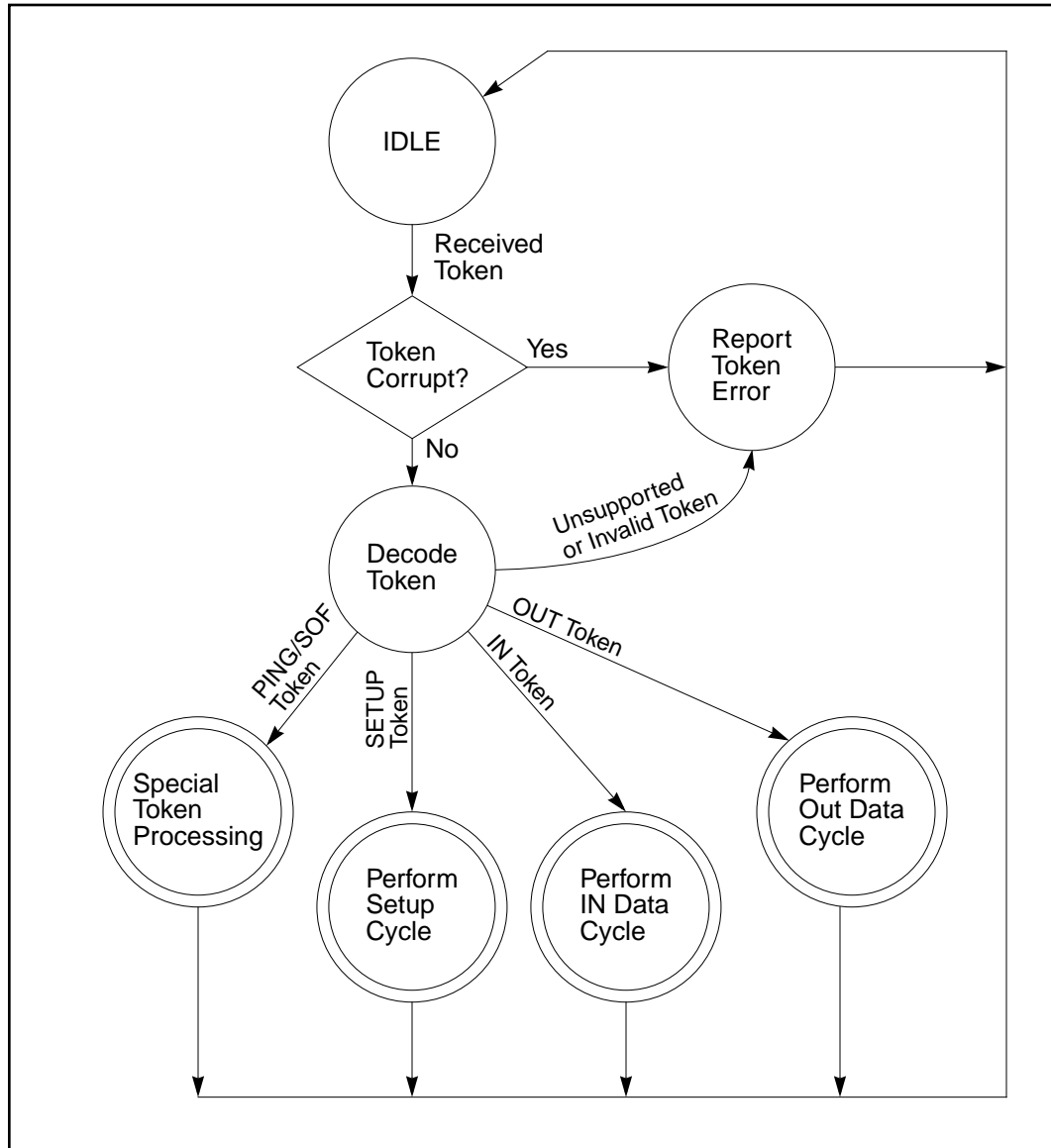

3.6.1. Special Token Processing

The USB Core currently supports only two special tokens in addition to SETUP, IN and OUT tokens. These tokens are SOF and PING. When a SOF token is received, the FRM_NAT register is updated.

The PING token is a special query token for high speed OUT endpoints. It allows the host to query whether there is space in the output buffer or not.

Figure 9: Special Token Processing Flowchart

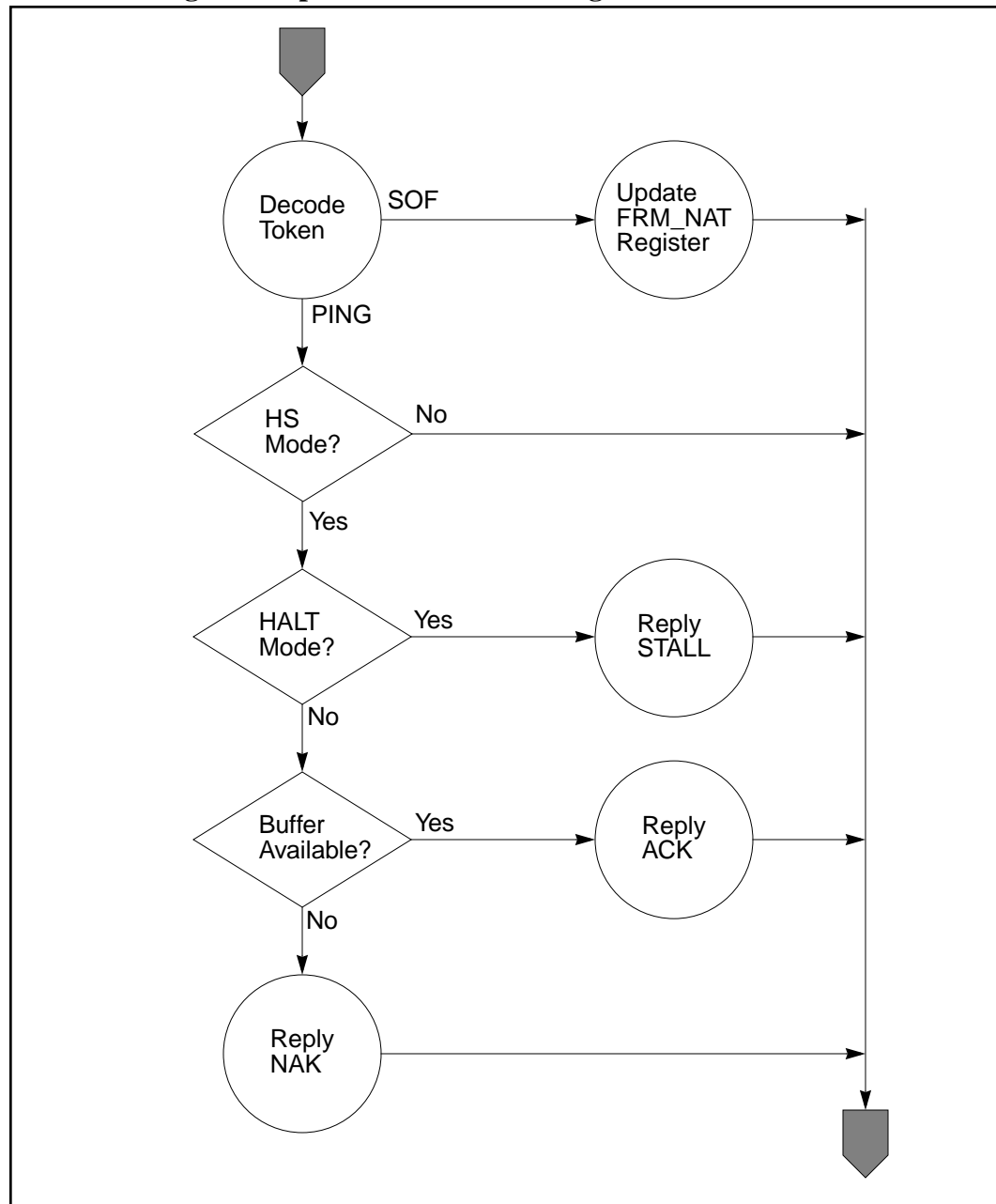

3.6.2. IN Data Cycle

This section illustrates the decision flow for an IN token.

Figure 10: IN Data Cycle Flowchart

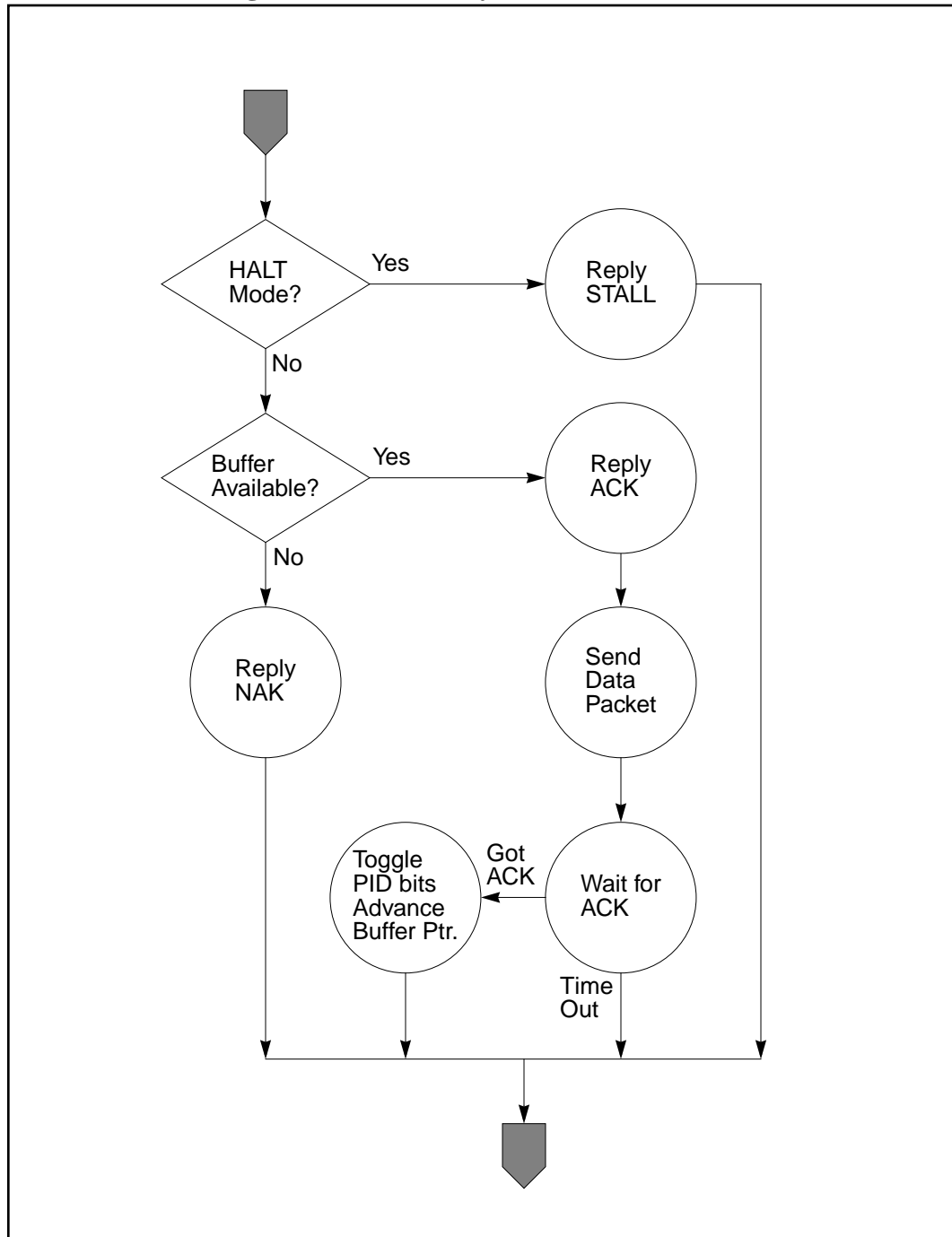

3.6.3. Out Data Cycle

This section illustrates the decision flow for an OUT token.

Figure 11: Out Data Cycle Flowchart

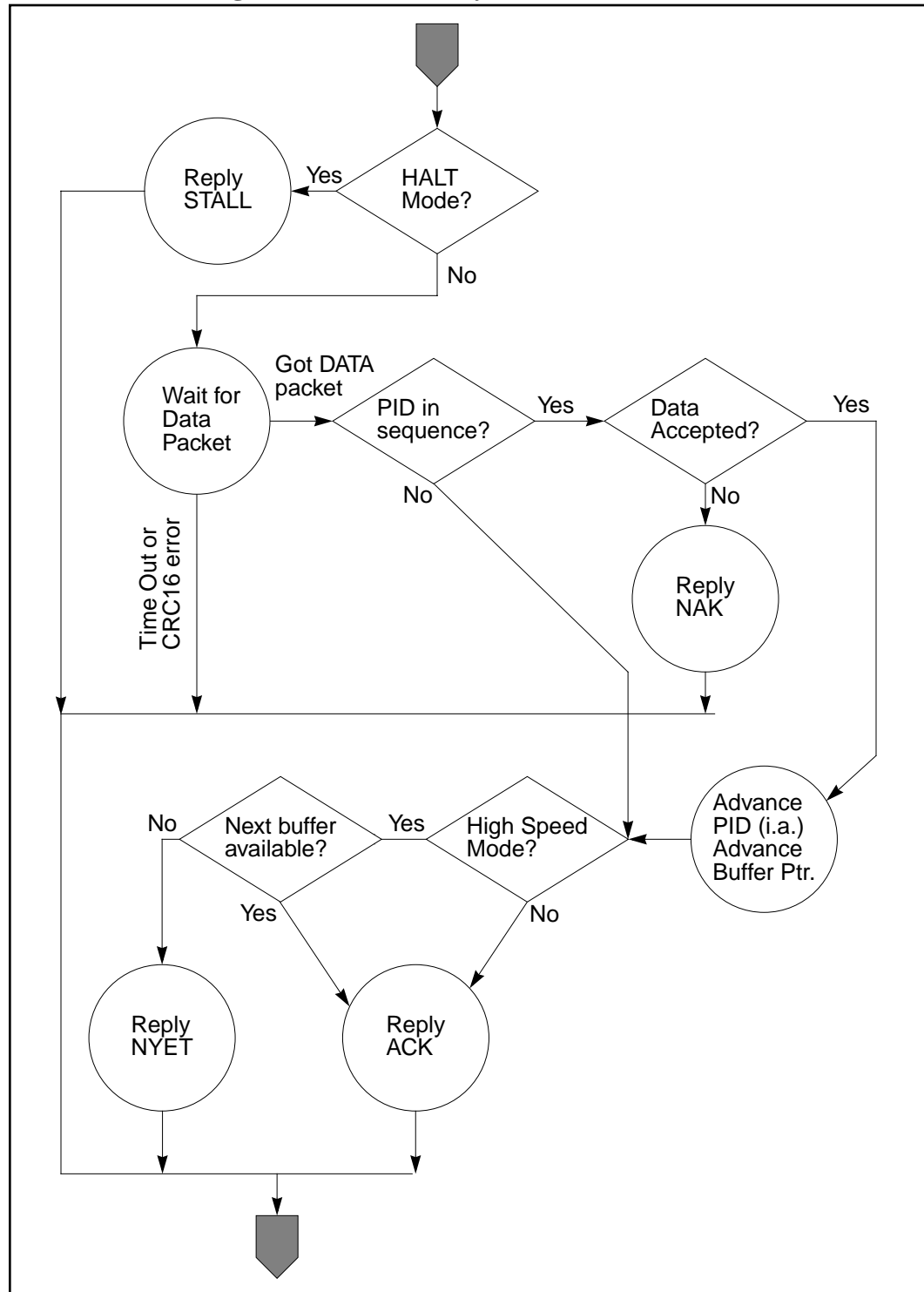

3.6.4. USB Device Control Processing

The USB provides a special mechanism to control the attached devices beyond data exchange. Those special controls are: Reset, Suspend/Resume and Speed Negotiation. Below flow chart illustrates the support provided by this USB core.

Figure 12: USB Device Control Processing

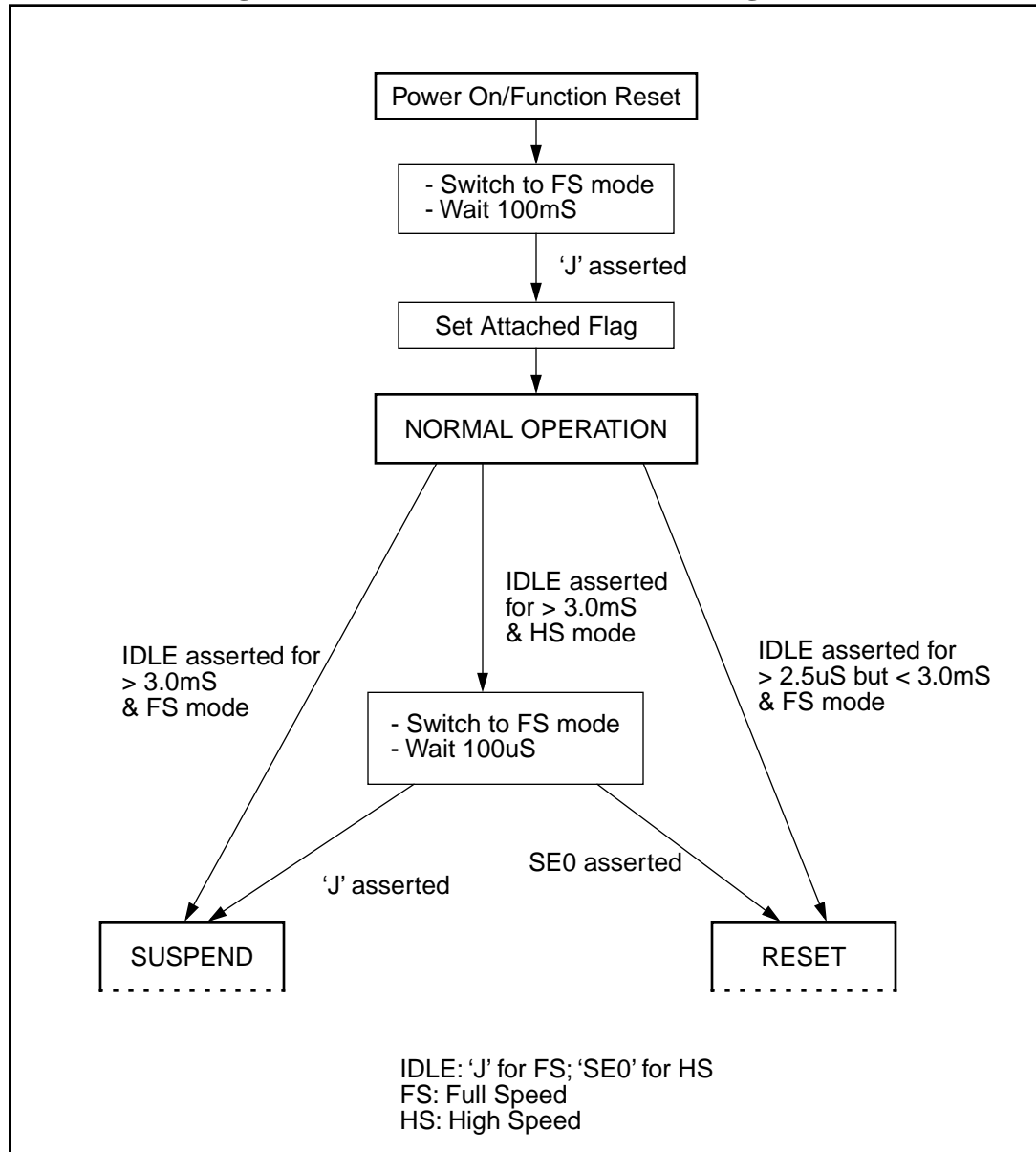

Figure 13: Suspend Control Processing

Figure 14: Reset Control Processing

3.7. Interrupts

The USB core provides two interrupt outputs (INT_A and INT_B). Both outputs are fully programmable. The programming for both outputs is identical to provide full flexibility to software. The intention is to have one high priority interrupt and one low priority interrupt. The actual usage of the interrupts is up to the system into which the USB core is incorporated.

The interrupt mechanism in the USB core consists of a two level hierarchy:

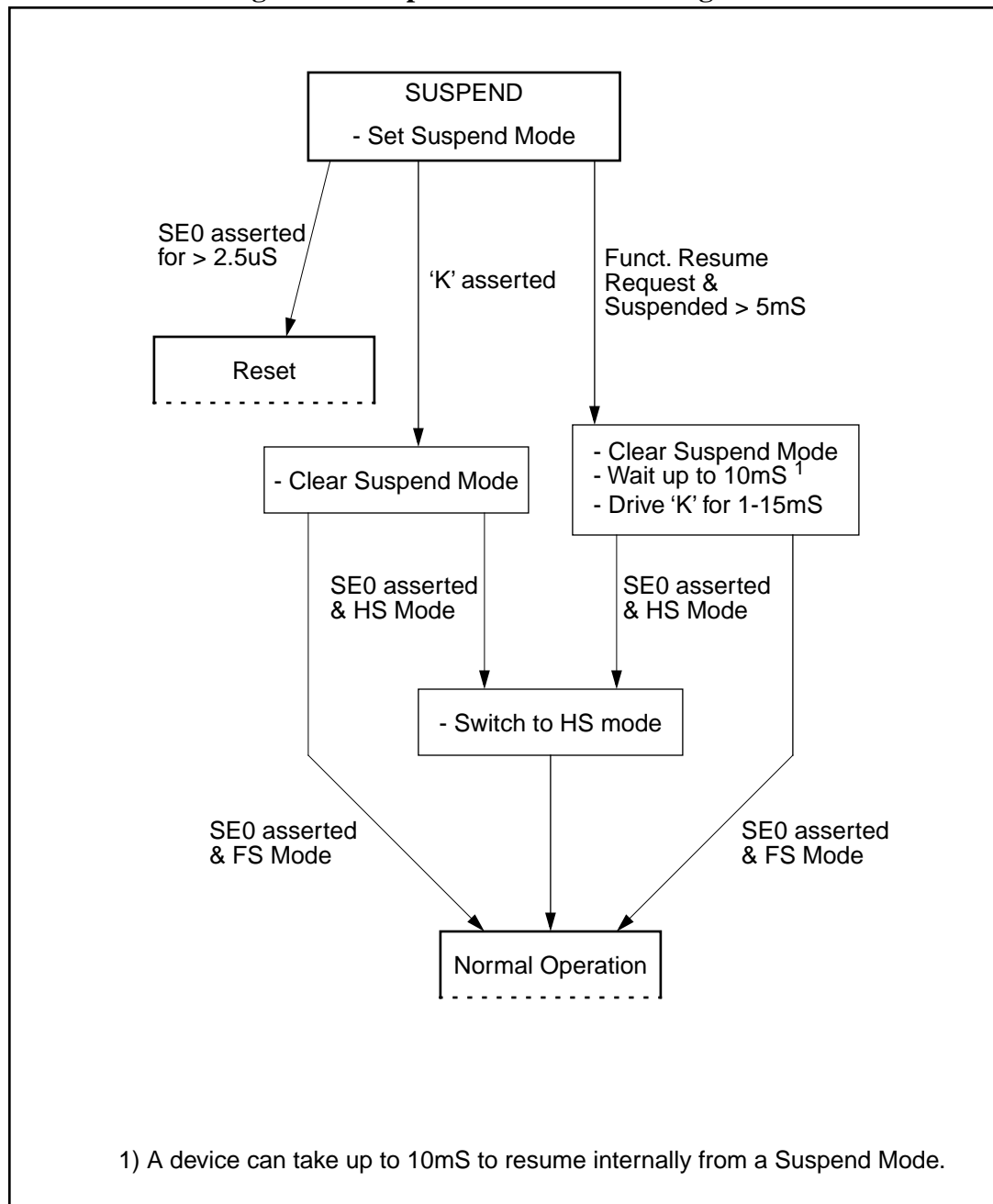
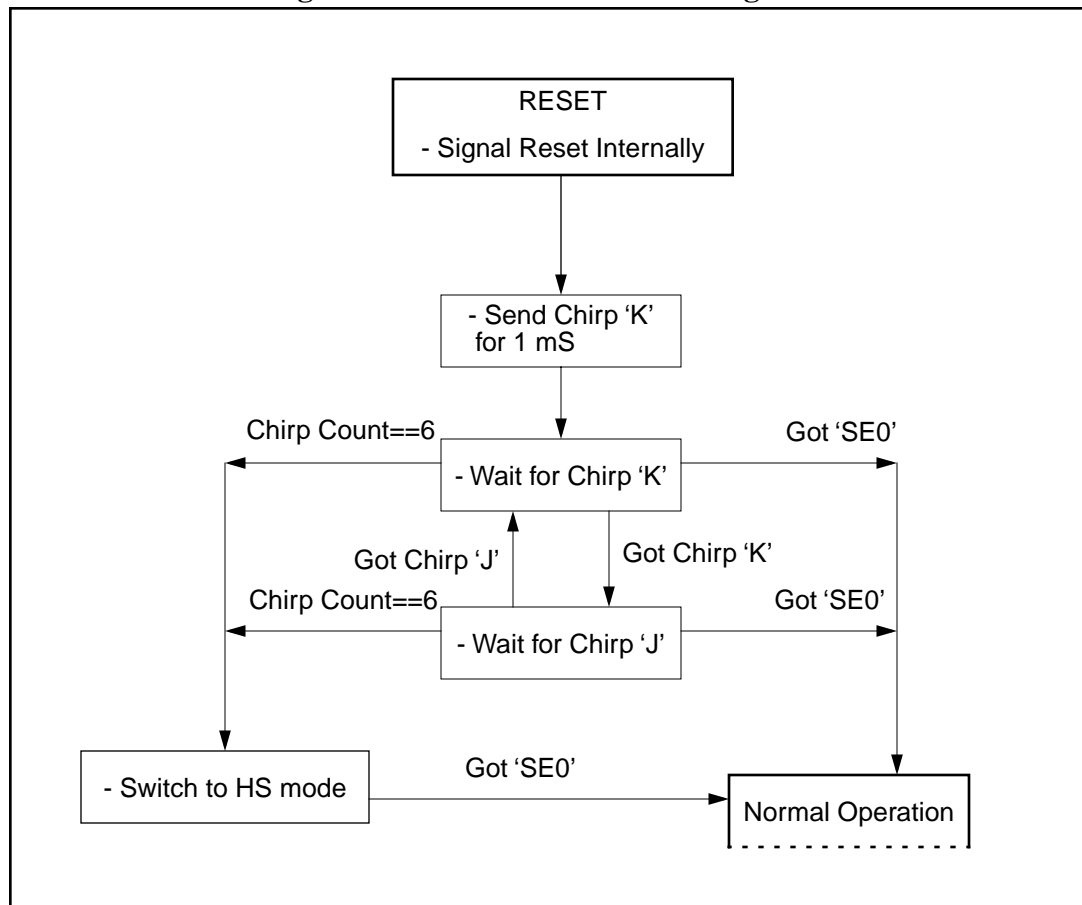
- The main interrupt source register (INT_SRC) indicates interrupts that are endpoint independent. These interrupts indicate overall events that have either global meaning for all endpoints or can not be associated with an endpoint because of an error condition.
- The endpoint interrupt source registers indicate events that are specific to an endpoint.

3.7.1. Timing

The interrupt outputs are asserted when the condition that is enabled in the interrupt mask occurs. They remain asserted until the main interrupt register is read.

3.7.2. Software Interaction

A interrupt handler should first read the main interrupt source register (INT_SRC) to determine the source of an interrupt. It must remember the value that was read until it is done, processing each interrupt source. If any of the bits 15 through 0 are set, the interrupt handler should also read the appropriate endpoint interrupt register to determine endpoint specific events. Multiple interrupt sources may be indicated at any given time. Software should be prepared to handle every interrupt source it cares about.

Note:

When using both interrupt pins to service different events, or prioritizing event handling, care must be taken not to lose interrupt sources, as the main interrupt source register is cleared after a read.

3.8. Suspend & Resume

USB defines a protocol for suspending devices that are attached to the UCB bus. Devices that are powered by USB bus must enter a low power mode when a suspend signaling has been received. The USB core will assert and hold asserted the SUSP_O for as long as the device must remain in the suspended state.

A device that has entered suspend mode can be “woken up” in two different ways:

1. Resume Signaling from the USB.
2. Asserting the RESUME_REQ_I line.

(This page intentionally left blank)

4

Core Registers

This section describes all control and status registers inside the USB function. The *Address* field indicates a relative address in hexadecimal. *Width* specifies the number of bits in the register, and *Access* specifies the valid access types to that register. RW stands for read and write access, RO for read only access. A 'C' appended to RW or RO indicates that some or all of the bits are cleared after a read.

Table 2: Control/Status Registers

Name	Addr.	Width	Access	Description
CSR	0	32	RW	Control/Status Register
FA	4	32	RW	Function Address
INT_MSK	8	32	RW	Interrupt Mask for endpoint independent sources
INT_SRC	C	32	ROC	Interrupt Source register
FRM_NAT	10	32	RO	Frame Number and Time
UTMI_VEND	14	32	RW	Vendor Specific IO port
Endpoint Registers				
EP0_CSR	40	32	RW	Endpoint 0: CSR
EP0_INT	44	32	RW	Endpoint 0: Interrupt Register
EP0_BUF0	48	32	RW	Endpoint 0: Buffer Register 0
EP0_BUF1	4c	32	RW	Endpoint 0: Buffer Register 1
EP1_CSR	50	32	RW	Endpoint 1: CSR
EP1_INT	54	32	RW	Endpoint 1: Interrupt Register
EP1_BUF0	58	32	RW	Endpoint 1: Buffer Register 0
EP1_BUF1	5c	32	RW	Endpoint 1: Buffer Register 1
EP2_CSR	60	32	RW	Endpoint 2: CSR
EP2_INT	64	32	RW	Endpoint 2: Interrupt Register

Table 2: Control/Status Registers

Name	Addr.	Width	Access	Description
EP2_BUF0	68	32	RW	Endpoint 2: Buffer Register 0
EP2_BUF1	6c	32	RW	Endpoint 2: Buffer Register 1
EP3_CSR	70	32	RW	Endpoint 3: CSR
EP3_INT	74	32	RW	Endpoint 3: Interrupt Register
EP3_BUF0	78	32	RW	Endpoint 3: Buffer Register 0
EP3_BUF1	7c	32	RW	Endpoint 3: Buffer Register 1
EP4_CSR	80	32	RW	Endpoint 4: CSR
EP4_INT	84	32	RW	Endpoint 4: Interrupt Register
EP4_BUF0	88	32	RW	Endpoint 4: Buffer Register 0
EP4_BUF1	8c	32	RW	Endpoint 4: Buffer Register 1
EP5_CSR	90	32	RW	Endpoint 5: CSR
EP5_INT	94	32	RW	Endpoint 5: Interrupt Register
EP5_BUF0	98	32	RW	Endpoint 5: Buffer Register 0
EP5_BUF1	9c	32	RW	Endpoint 5: Buffer Register 1
EP6_CSR	a0	32	RW	Endpoint 6: CSR
EP6_INT	a4	32	RW	Endpoint 6: Interrupt Register
EP6_BUF0	a8	32	RW	Endpoint 6: Buffer Register 0
EP6_BUF1	ac	32	RW	Endpoint 6: Buffer Register 1
EP7_CSR	b0	32	RW	Endpoint 7: CSR
EP7_INT	b4	32	RW	Endpoint 7: Interrupt Register
EP7_BUF0	b8	32	RW	Endpoint 7: Buffer Register 0
EP7_BUF1	bc	32	RW	Endpoint 7: Buffer Register 1
EP8_CSR	c0	32	RW	Endpoint 8: CSR
EP8_INT	c4	32	RW	Endpoint 8: Interrupt Register
EP8_BUF0	c8	32	RW	Endpoint 8: Buffer Register 0
EP8_BUF1	cc	32	RW	Endpoint 8: Buffer Register 1
EP9_CSR	d0	32	RW	Endpoint 9: CSR
EP9_INT	d4	32	RW	Endpoint 9: Interrupt Register
EP9_BUF0	d8	32	RW	Endpoint 9: Buffer Register 0
EP9_BUF1	dc	32	RW	Endpoint 9: Buffer Register 1
EP10_CSR	e0	32	RW	Endpoint 10: CSR
EP10_INT	e4	32	RW	Endpoint 10: Interrupt Register

Table 2: Control/Status Registers

Name	Addr.	Width	Access	Description
EP10_BUF0	e8	32	RW	Endpoint 10: Buffer Register 0
EP10_BUF1	ec	32	RW	Endpoint 10: Buffer Register 1
EP11_CSR	f0	32	RW	Endpoint 11: CSR
EP11_INT	f4	32	RW	Endpoint 11: Interrupt Register
EP11_BUF0	f8	32	RW	Endpoint 11: Buffer Register 0
EP11_BUF1	fc	32	RW	Endpoint 11: Buffer Register 1
EP12_CSR	100	32	RW	Endpoint 12: CSR
EP12_INT	104	32	RW	Endpoint 12: Interrupt Register
EP12_BUF0	108	32	RW	Endpoint 12: Buffer Register 0
EP12_BUF1	10c	32	RW	Endpoint 12: Buffer Register 1
EP13_CSR	110	32	RW	Endpoint 13: CSR
EP13_INT	114	32	RW	Endpoint 13: Interrupt Register
EP13_BUF0	118	32	RW	Endpoint 13: Buffer Register 0
EP13_BUF1	11c	32	RW	Endpoint 13: Buffer Register 1
EP14_CSR	120	32	RW	Endpoint 14: CSR
EP14_INT	124	32	RW	Endpoint 14: Interrupt Register
EP14_BUF0	128	32	RW	Endpoint 14: Buffer Register 0
EP14_BUF1	12c	32	RW	Endpoint 14: Buffer Register 1
EP15_CSR	130	32	RW	Endpoint 15: CSR
EP15_INT	134	32	RW	Endpoint 15: Interrupt Register
EP15_BUF0	138	32	RW	Endpoint 15: Buffer Register 0
EP15_BUF1	13c	32	RW	Endpoint 15: Buffer Register 1

4.1. Control Status Register (CSR)

This is the main configuration and status register of the USB core.

Table 3: CSR Register

Bit #	Access	Description
7:5	RO	RESERVED
4:3	RO	UTMI Line State
2	RO	Interface Status 1=Attached

Table 3: CSR Register

Bit #	Access	Description
1	RO	Interface Speed 1=High Speed Mode; 0=Full Speed Mode
0	RO	1=Suspend Mode

Value after reset:

CSR: 00 h

4.2. Function Address Register (FA)

The function address is set by the function controller when the function is configured. This is done by exchanging control and status information with the host.

Value after reset:

FA: 00h

4.3. Interrupt Mask Register (INT_MSK)

The interrupt mask register defines the functionality of int_a and int_b outputs in regard to events without associated endpoints.

A bit set to a logical 1 enables the generation of the interrupt for that source, a zero disables the generation of an interrupt.

Table 4: Interrupt Mask Register

Bit #	Access	Description
31:25	RO	RESERVED
24	RW	Interrupt B Enable: Received a USB Reset
23	RW	Interrupt B Enable: Received a UTMI Rx Error
22	RW	Interrupt B Enable: Assert interrupt when Detached
21	RW	Interrupt B Enable: Assert interrupt when Attached
20	RW	Interrupt B Enable: Leave Suspend Mode (Resume)
19	RW	Interrupt B Enable: Enter Suspend Mode (Suspend)
18	RW	Interrupt B Enable: No Such Endpoint
17	RW	Interrupt B Enable: PID Error (PID check sum error)
16	RW	Interrupt B Enable: Bad Token (CRC 5 error)
15:9	RO	RESERVED

Table 4: Interrupt Mask Register

Bit #	Access	Description
8	RW	Interrupt A Enable: Received a USB reset
7	RW	Interrupt A Enable: Received a UTMI Rx Error
6	RW	Interrupt A Enable: Assert interrupt when Detached
5	RW	Interrupt A Enable: Assert interrupt when Attached
4	RW	Interrupt A Enable: Leave Suspend Mode (Resume)
3	RW	Interrupt A Enable: Enter Suspend Mode (Suspend)
2	RW	Interrupt A Enable: No such endpoint
1	RW	Interrupt A Enable: PID Error (PID check sum error)
0	RW	Interrupt A Enable: Bad Token (CRC 5 error)

Value after reset:

INT_MSK: 0000h

4.4. Interrupt Source Register (INR_SRC)

This register identifies the source of an interrupt. Whenever the function controller receives an interrupt, the interrupt handler must read this register to determine the source and cause of the interrupt. Some of the bits in this register will be cleared after a read. The software interrupt handler must make sure it keeps whatever information is required to handle the interrupt.

Table 5: Interrupt Source Register

Bit #	Access	Description
31:29	RO	RESERVED
28	ROC	USB Reset
27	ROC	UTMI Rx Error
26	ROC	Detached
25	ROC	Attached
24	ROC	Resume
23	ROC	Suspend
22	ROC	No Such Endpoint
21	ROC	PID Error (PID check sum error)
20	ROC	Bad Token (CRC 5 error)

Table 5: Interrupt Source Register

Bit #	Access	Description
19:16	RO	RESERVED
15	RO	Endpoint 15 caused an Interrupt
14	RO	Endpoint 14 caused an Interrupt
13	RO	Endpoint 13 caused an Interrupt
12	RO	Endpoint 12 caused an Interrupt
11	RO	Endpoint 11 caused an Interrupt
10	RO	Endpoint 10 caused an Interrupt
9	RO	Endpoint 9 caused an Interrupt
8	RO	Endpoint 8 caused an Interrupt
7	RO	Endpoint 7 caused an Interrupt
6	RO	Endpoint 6 caused an Interrupt
5	RO	Endpoint 5 caused an Interrupt
4	RO	Endpoint 4 caused an Interrupt
3	RO	Endpoint 3 caused an Interrupt
2	RO	Endpoint 2 caused an Interrupt
1	RO	Endpoint 1 caused an Interrupt
0	RO	Endpoint 0 caused an Interrupt

Value after reset:

INT_SRC: 0000h

4.5. Frame Number and time register (FRM_NAT)

This register tracks the frame number as received from the SOF token, and the frame time.

Table 6: Frame Number and Time Register

Bit #	Access	Description
31:28	RO	Number of frames with the same frame number (this field may be used to determine current microframe)
27	RO	Reserved
26:16	RO	Frame number as received from SOF token
15:12	RO	Reserved

Table 6: Frame Number and Time Register

Bit #	Access	Description
11:0	RO	Time since last SOF in 0.5 uS resolution

Value after reset:

FRM_NAT: 0000h

4.6. Vendor Specific IO Port (UTMI_VEND)

The UTMI specification allows for a vendor defined IO port. This port consists of a 4 bit write port (to the UTMI device) and an 8 bit status port (status of the UTMI device). This register provides access to this vendor specific control/status port. A write to this register will write bits 3:0 to the VControl bus and assert VControlLoad line. A read from this register will return the value present on the VStatus lines 7:0. The actual meaning of the control and status bits is vendor specific and should be determined from the UTMI device vendors specification.

4.7. Endpoint Registers

Each endpoint has 4 registers associated with it. These registers have exactly the same definition for each endpoint.

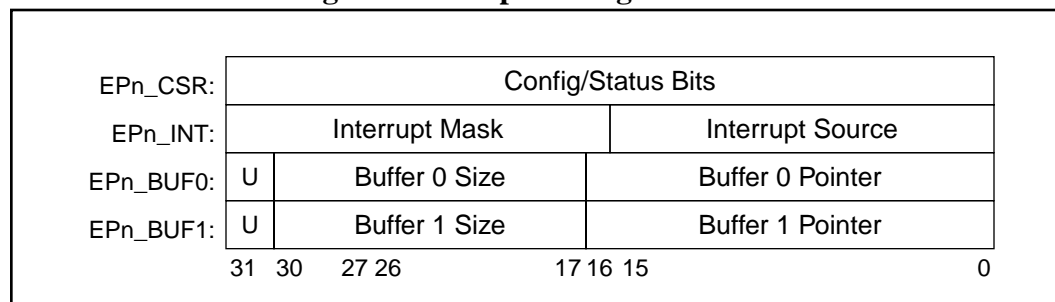
Figure 15: Endpoint Registers

4.7.1. Endpoint CSR Register (EP_CSR)

The configuration and status bits specify the operation mode of the endpoint and report any specific endpoint status back to the controller.

Table 7: Endpoint CSR

Bit #	Access	Description
31:30	RO	UC_BSEL Buffer Select This bits must be initialized to zero (first Buffer 0 is used). The USB core will toggle these bits, in order to know which buffer to use for the next transaction. 00: Buffer 0 01: Buffer 1 1x: RESERVED
29:28	RO	UC_DPD These two bits are used by the USB core to keep track of the data PIDs for high speed endpoints and for DATA0/DATA1 toggling.
27:26	RW	EP_TYPE Endpoint Type 00: Control Endpoint 01: IN Endpoint 10: OUT Endpoint 11: RESERVED
25:24	RW	TR_TYPE Transfer Type 00: Interrupt 01: Isochronous 10: Bulk 11: RESERVED
23:22	RW	EP_DIS Temporarily Disable The Endpoint 00: Normal Operation 01: Force the core to ignore all transfers to this endpoint 10: Force the endpoint in to HALT state 11: RESERVED
21:18	RW	EP_NO Endpoint Number
17	RW	LRG_OK 1 - Accept data packets of more than MAX_PL_SZ bytes (RX only) 0 - Ignore data packet with more than MAXPL_SZ bytes (RX only)
16	RW	SML_OK 1 - Accept data packets with less than MAX_PL_SZ bytes (RX only) 0 - Ignore data packet with less than MAXPL_SZ bytes (RX only)

Table 7: Endpoint CSR

Bit #	Access	Description
15	RW	DMAEN 1: Enables external DMA interface and operation 0: No DMA operation
14	RO	RESERVED
13	RW	OTS_STOP When set, this bit enables the disabling of the endpoint when in DMA mode, an OUT endpoint receives a packet smaller than MAX_PL_SZ. The disabling is achieved by setting EP_DIS to 01b
12:11	RW	TR_FR Number of transactions per micro frame (HS mode only)
10:0	RW	MAX_PL_SZ Maximum payload size (MaxPacketSize) in bytes

Value after reset:

EPn_CSR: 0000h

4.7.2. Endpoint Interrupt Mask/Source Register (EP_IMS)

The interrupt register for each endpoint has mask bits for interrupt int_a and interrupt int_b outputs and bits that indicate the interrupt source when an interrupt has been received.

Table 8: Endpoint Interrupt Register

Bit #	Access	Description
31:30	RO	RESERVED
29	RW	Interrupt A Enable: OUT packet smaller than MAX_PL_SZ
28	RW	Interrupt A Enable: PID Sequencing Error
27	RW	Interrupt A Enable: Buffer Full/Empty
26	RW	Interrupt A Enable: Unsupported PID
25	RW	Interrupt A Enable: Bad packet (CRC 16 error)
24	RW	Interrupt A Enable: Time Out (waiting for ACK or DATA packet)
23:22	RO	RESERVED
21	RW	Interrupt B Enable: OUT packet smaller than MAX_PL_SZ
20	RW	Interrupt B Enable: PID Sequencing Error
19	RW	Interrupt B Enable: Buffer Full/Empty

Table 8: Endpoint Interrupt Register

Bit #	Access	Description
18	RW	Interrupt B Enable: Unsupported PID
17	RW	Interrupt B Enable: Bad packet (CRC 16 error)
16	RW	Interrupt B Enable: Time Out (waiting for ACK or DATA packet)
15:7	RO	RESERVED
6	ROC	Interrupt Status: OUT packet smaller than MAX_PL_SZ
5	ROC	Interrupt Status: PID Sequencing Error
4	ROC	Interrupt Status: Buffer 1 Full/Empty
3	ROC	Interrupt Status: Buffer 0 Full/Empty
2	ROC	Interrupt Status: Unsupported PID
1	ROC	Interrupt Status: Bad packet (CRC 16 error)
0	ROC	Interrupt Status: Time Out (waiting for ACK or DATA packet)

Value after reset:

EPn_INT: 0000h

4.7.3. Endpoint Buffer Registers (EP_BUF)

The endpoint buffer registers hold the buffer pointers for each endpoint. Each endpoint has two buffer registers, thus allowing double buffering. Each buffer register has exactly the same definition and functionality (see discussion in section 3.1.1. “Buffer Pointers” on page 10 for more information).

Table 9: Endpoint Buffer Register

Bit #	Access	Description
31	RW	USED This bit is set by the USB core after it has used this buffer. The function controller must clear this bit again after it has emptied/refilled this buffer. This bit must be initialized to 0.
30:17	RW	BUF_SZ Buffer size (number of bytes in the buffer) 16383 bytes max.
16:0	RW	BUF_PTR Buffer pointer (byte address of the buffer)

Value after reset:

EPn_BUFm: FFFFFFFFh

5

Core IOs

This chapter lists all IOs of the USB core. Each clock domain is contained in a separate subsection.

5.1. Host Interface IOs

The host interface is a WISHBONE Rev. B compliant interface. This USB core works as a slave device only. When the intervention of the local microcontroller is needed, it will assert INTA_O or INTB_O.

Table 10: Host Interface (WISHBONE)

Name	Width	Direction	Description
CLK_I	1	I	Clock Input
RST_I	1	I	Reset Input
ADDR_I	18	I	Address Input See Appendix A "Core HW Configuration" on page 41 for more information.
DATA_I	32	I	Data Input
DATA_O	32	O	Data Output
ACK_O	1	O	Acknowledgment Output. Indicates a normal Cycle termination.
WE_I	1	I	Indicates a Write Cycle when asserted high.
STB_I	1	I	Indicates the beginning of a valid transfer cycle for this core.
CYC_I	1	I	Encapsulates an valid transfer cycle
Below signals extend the WISHBONE SoC standard interface.			
INTA_O	1	O	Interrupt Output A
INTB_O	1	O	Interrupt Output A
DMA_REQ	15	O	DMA Request For each endpoint one line. Unused endpoints will tie their DMA_REQ output to zero.

Table 10: Host Interface (WISHBONE)

Name	Width	Direction	Description
DMA_ACK	15	I	DMA Acknowledgement For each endpoint one line. Unused endpoints will ignore their DMA_ACK line.
SUSP_O	1	O	Suspend Output
RESUME_R EQ_I	1	I	Resume Request (Connect to 0 (zero) when not used.)

Address line 17 selects between the core's buffer memory and register file. When asserted high, the memory buffer is selected, when low, the register file.

5.2. UTMI IOs

The UTMI interface is a USB 2.0 UTMI specification Version 1.04 compliant interface.

Table 11: UTMI Interface

Name	Width	Direction	Description
phy_clk	1	I	Clock
phy_rst	1	O	Reset Output
DataIn	8	I	Input Data
DataOut	8	O	Output Data
TxValid	1	O	Transmit Valid
TxReady	1	I	Transmit Ready
RxActive	1	I	Receiver Active
RxValid	1	I	Receive Data Valid
RxError	1	I	Receive Error
XcvSelect	1	O	1: Full speed transceiver selected 0: High Speed transceiver selected
TermSel	1	O	1: Full speed termination enabled 0: High speed termination enabled
SuspendM	1	O	Places PHY into suspend mode
LineState	2	I	Line State
OpMode	2	O	Operation Mode Select
VControl-Load	1	O	Vendor Control Load

Table 11: UTMI Interface

Name	Width	Direction	Description
VControl	4	O	Vendor Control data
VStatus	8	I	Vendor Status data
Below signals extend the UTMI standard interface.			
usb_vbus	1	I	This signal should be connected to the Vcc pin of the USB connector. It is used to detect if the core is connected to an USB interface. This input can also be tight to the core Vcc line if the core is powered from the USB bus and this functionality is not needed.

5.3. Buffer Memory Interface

This is the interface to the buffer memory that is internally used by the USB core. It is a standard Synchronous SRAM.

Table 12: Synchronous SRAM Interface

Name	Width	Direction	Description
sram_adr	14	O	SRAM Address lines See Appendix A "Core HW Configuration" on page 41 for more information.
sram_dout	32	O	Output Data (To SRAM)
sram_din	32	I	Input Data (From SRAM)
sram_re	1	O	SRAM Read Enable
sram_we	1	O	SRAM Write Enable

The SRAM must use the PHY clock (phy_clk) as its clock input.

(This page intentionally left blank)

Appendix A

Core HW Configuration

This Appendix describes the configuration of the core. This step is performed before final synthesis and tape-out of the USB core.

A.1. Endpoints

This core supports up to 16 individual endpoints. The actual functionality of each endpoint is under function software control. An implementation may choose how many endpoints it actually wants to support. The minimum number is 1 endpoint (Endpoint 0 must be always present), the maximum number of endpoints for this USB core is 16 (inclusive endpoint 0).

To select the endpoints to be supported edit the “usb_defines.v” file. Look for the following define statements:

```
`define    HAVE_EP1    1    // Endpoint 1 Present
`define    HAVE_EP2    1    // Endpoint 2 Present
`define    HAVE_EP3    1    // Endpoint 3 Present
`define    HAVE_EP4    1    // Endpoint 4 Present
`define    HAVE_EP5    1    // Endpoint 5 Present
`define    HAVE_EP6    1    // Endpoint 6 Present
`define    HAVE_EP7    1    // Endpoint 7 Present
`define    HAVE_EP8    1    // Endpoint 8 Present
//`define  HAVE_EP9    1    // Endpoint 9 NOT Present
//`define  HAVE_EP10   1    // Endpoint 10 NOT Present
//`define  HAVE_EP11   1    // Endpoint 11 NOT Present
//`define  HAVE_EP12   1    // Endpoint 12 NOT Present
//`define  HAVE_EP13   1    // Endpoint 13 NOT Present
//`define  HAVE_EP14   1    // Endpoint 14 NOT Present
//`define  HAVE_EP15   1    // Endpoint 15 NOT Present
```

For each endpoint that should be present in the USB core, un-comment the define statement. The “HAVE_EPn” tag indicates that an endpoint is present when it is defined. The number “n” in the tag indicates the physical endpoint number (which should not be confused with the logical endpoint number, which can be set by software).

Endpoints must be defined sequential. In other words you must NOT define endpoints 1, 4 and 6, and comment out endpoints 2,3 and 5.

A.2. USB Core WISHBONE Address Lines

The Address encoding and WISHBONE interface address bus size may also be customized. Depending on the Buffer Memory size and the number of endpoints, the address bus size may be reduced, or enlarged. The minimum Address bus size must be able to address the buffer memory and select between the buffer memory and register file.

To modify the address bus size and decode logic, edit the “usb_defines.v” file, and look for the following lines:

```
`define    UFC_HADR    17
`define    RF_SEL      (!wb_addr_i[17])
`define    MEM_SEL     (wb_addr_i[17])
```

The first define statement specifies the MSB of the address bus coming into the USB core. With this setup, the core can support 128K bytes of buffer memory and has one address line available to distinguish between Register File and Buffer Memory Accesses.

The second define statement specifies how the USB core decodes register file accesses. The “wb_addr_i” bus is the WISHBONE address bus. Any simple combinatorial statement is permitted here.

The third define statement specifies how the USB core decodes memory buffer accesses. Again, any simple combinatorial statement is permitted.

Example

An application may choose to extend the address bus width by setting UFC_HADR to 20. This means wb_addr_i will be 21 bits wide [20:0].

```
`define    UFC_HADR    20
```

Then the RF_SEL may be set to (wb_addr_i[20:17] == 4'h3) and MEM_SEL to (wb_addr_i[20:17] == 4'h7).

```
`define    RF_SEL      (wb_addr_i[20:17]==4'h3)
`define    MEM_SEL     (wb_addr_i[20:17]==4'h7)
```

This means the register file will be in the address space 0x60000 through 0x7FFFF and the buffer memory in 0xE0000 through 0xFFFFF.

A.3. Buffer Memory

This USB core supports up to 128 Kilobytes of buffer memory. The minimum memory size should be at least 256 bytes. The memory is organized in 4 byte boundaries (words). This means a 4Kbyte buffer would be organized as 1024 * 32bit entries. The memory must always start at address zero of the USB core and must be continued up to the last address.

To modify the buffer memory size, edit the “usb_defines.v” file, and look for the following line:

```
`define    SSRAM_HADR  14
```

This statement specifies the MSB of the SSRAM address lines. In this case the SSRAM will have 15 address lines [14:0], and be 2^{15} (32K) words (4 byte quantities) large.

Alternatively this can be overwritten by parameterizing the USB core when instantiating it:

```
usb_top #(SRAM_ADR_MSB) u0 (<IO list>);
```

Now the value of SRAM_ADR_MSB will overwrite the setting of the define statement.

(This page intentionally left blank)

Appendix B

USB Core Structure

This section outlines the hierarchy structure of the USB core Verilog Source files.

Figure 16: USB Core Hierarchy Structure

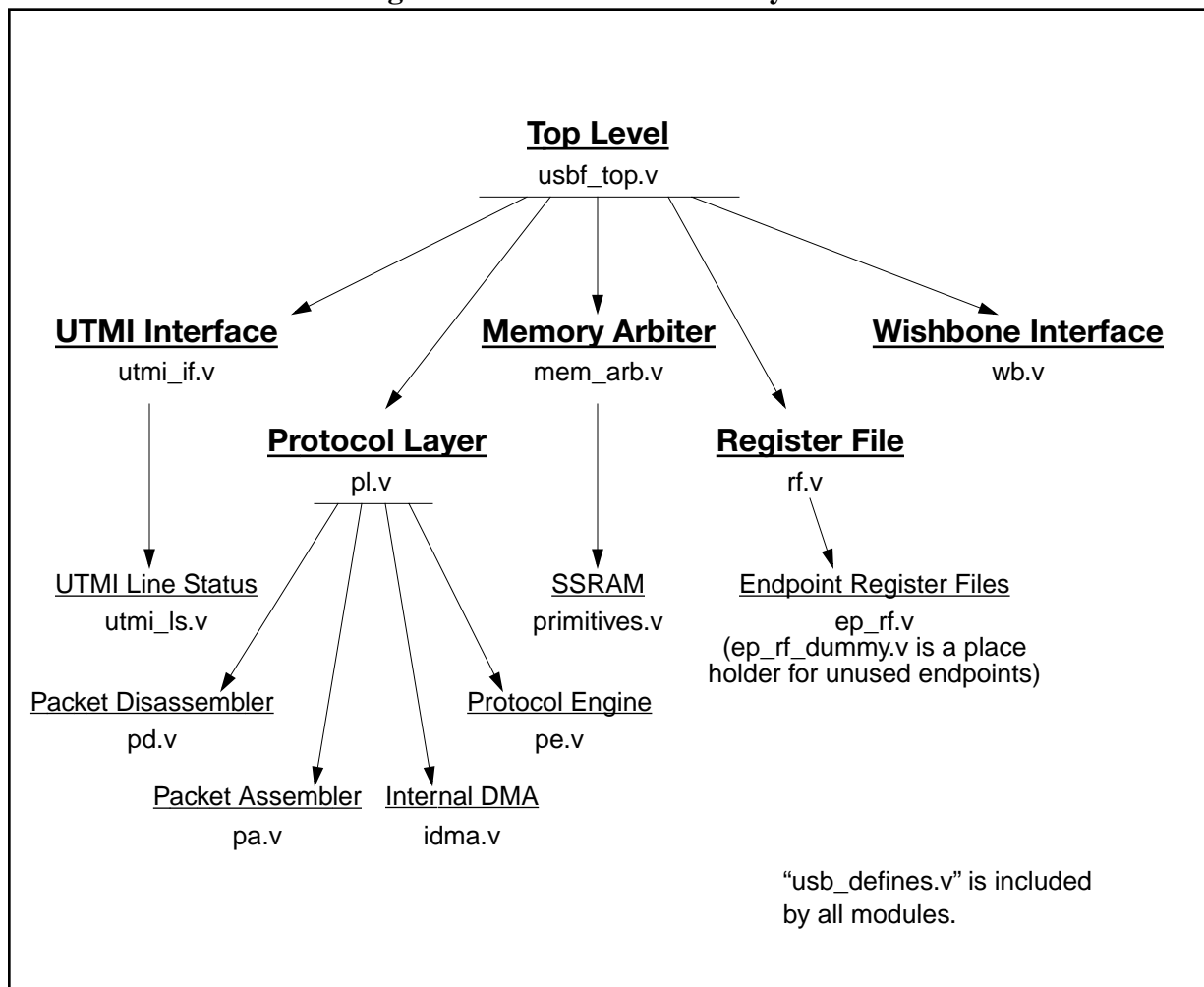

(This page intentionally left blank)

Appendix C

SSRAM Interface

This section describes the buffer memory interface and timing. The buffer memory is a standard single ported Synchronous SRAM.

Figure 17: SSRAM Read Cycle

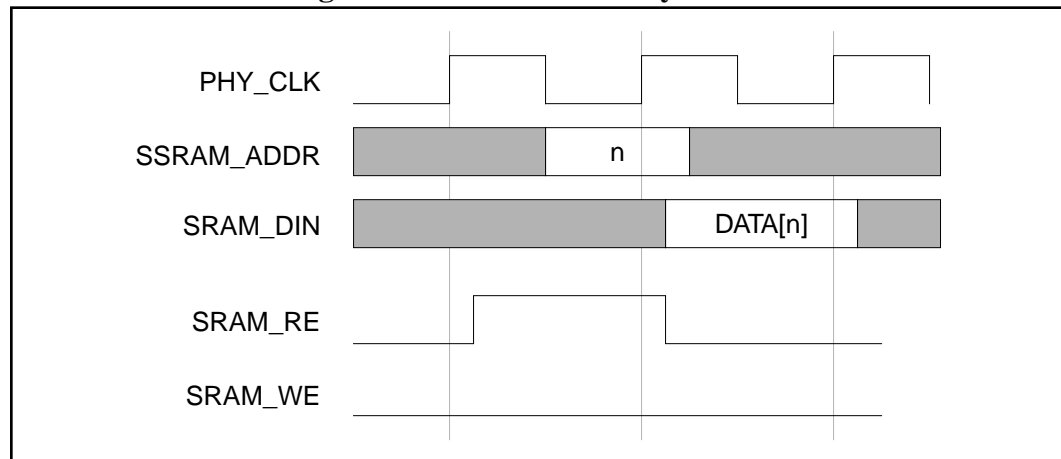
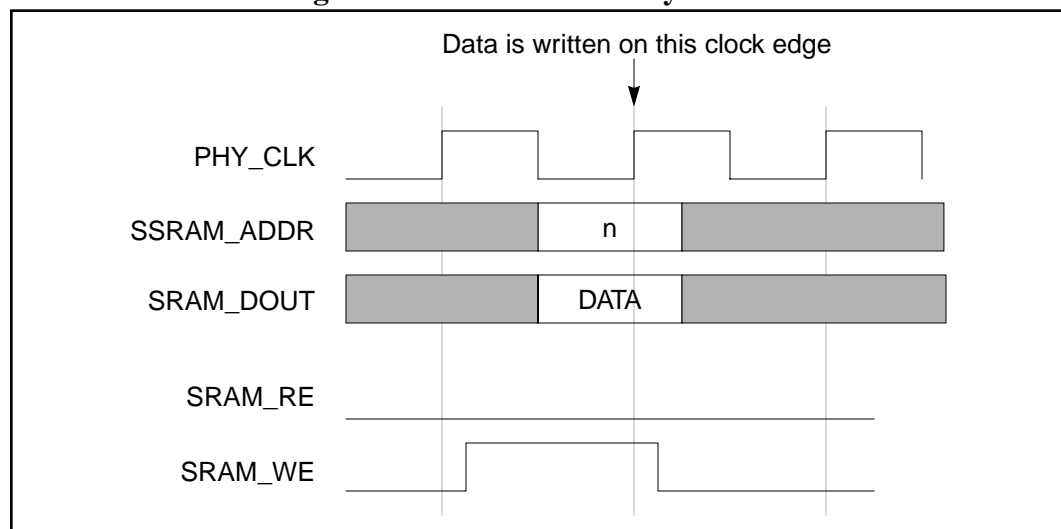

Figure 18: SSRAM Write Cycle



(This page intentionally left blank)

Appendix D

UTMI PHY

This core requires an external PHY (transceiver) that complies with the UTMI specification.

The UTMI specification can be downloaded from:
http://developer.intel.com/technology/usb/download/2_0_xcvr_macrocell_1_03.pdf

The following companies have announced PHY chips:

Lucent: USS2X1
<http://www.lucent.com/micro/usb/usbdocs.html>
[30/3/2001 - I was informed that the Lucent (now Agere) PHY is shipping! I am in the process of acquiring some samples so I can build an FPGA prototype. RU]

NEC: uPD720120
<http://www.necel.com/home.nsf/Main?ReadForm&Multimedia+Products>

Philips: ISP1501
<http://www.semiconductors.philips.com/pip/isp1501-01/>

These are all I have found. If you know of others, please email me: rudi@asics.ws

(This page intentionally left blank)

Appendix E

Software Model

By Chris Ziomkowski (chris@asics.ws)

The embedded programming model consists of a low level driver that is either integrated into an embedded operating system or exists in a standalone configuration if an operating system is not necessary. The low level driver provides an abstracted interface to the hardware so that higher level modules can access the USB interface in a fashion consistent with other network interfaces, and represents the combined levels 2 and 3 in the OSI model.

The embedded system architecture is shown in “Figure 19: Embedded System Architecture” on page 53. Each interface of the device is logically independent, and must receive distinct endpoints as required by the USB 2.0 specification. The descriptors for the required interfaces and endpoints should be stored in a memory structure that is abstractly represented as a database in the figure. Since these assignments are generally fixed, it is assumed that the descriptors will be loaded from a flash or other permanent storage device. The low level driver will use this information to direct USB requests to the appropriate interface.

Device requests flow from the hardware serial interface engine through the hardware endpoint interface buffers to the low level device drivers. Messages destined for endpoint 0 first will be inspected by the USB dispatcher to determine if they are standard device requests or class/vendor specific requests. Standard device requests will be returned directly by the configuration and control subsystem. This generally consists of returning static information stored in the descriptor database. Class or vendor specific requests will be forwarded to the interface associated with the specified endpoint or interface. The interface will then be responsible for decoding the request and replying with the correct information.

Every endpoint interface consists of 0 or more endpoints. Each endpoint is assigned a stream style memory buffer which can buffer reads and writes for increased efficiency. The model assumes the high level interfaces are implementing blocking reads and writes. In this configuration, a bulk or control endpoint interface will be alerted to the end of transmission by a read returning 0 bytes. End of transmission during a write be assumed if flush() is called on the buffer with any

number of bytes (including 0) less than `MAX_PACKET_LENGTH`. Isochronous and interrupt endpoints do not have such limitations, as bytes will be read and written to these interfaces as they become available.

In addition to the endpoint streams, each interface includes a control message pipe connected to endpoint 0. Class and vendor device requests will be forwarded over this message pipe to the appropriate interface. Thus, endpoint 0 can be logically shared between all the interfaces in a device, and the USB dispatcher will guarantee atomicity during a transaction.

The exact implementation of the low level device drivers will be device and operating system dependent, however the following logical flow diagrams represents the expected behavior. The flow charts describe most of the operation of the USB dispatcher.

The high level interfaces should implement an API to the stream buffers as described in the Programmer's Guide document.

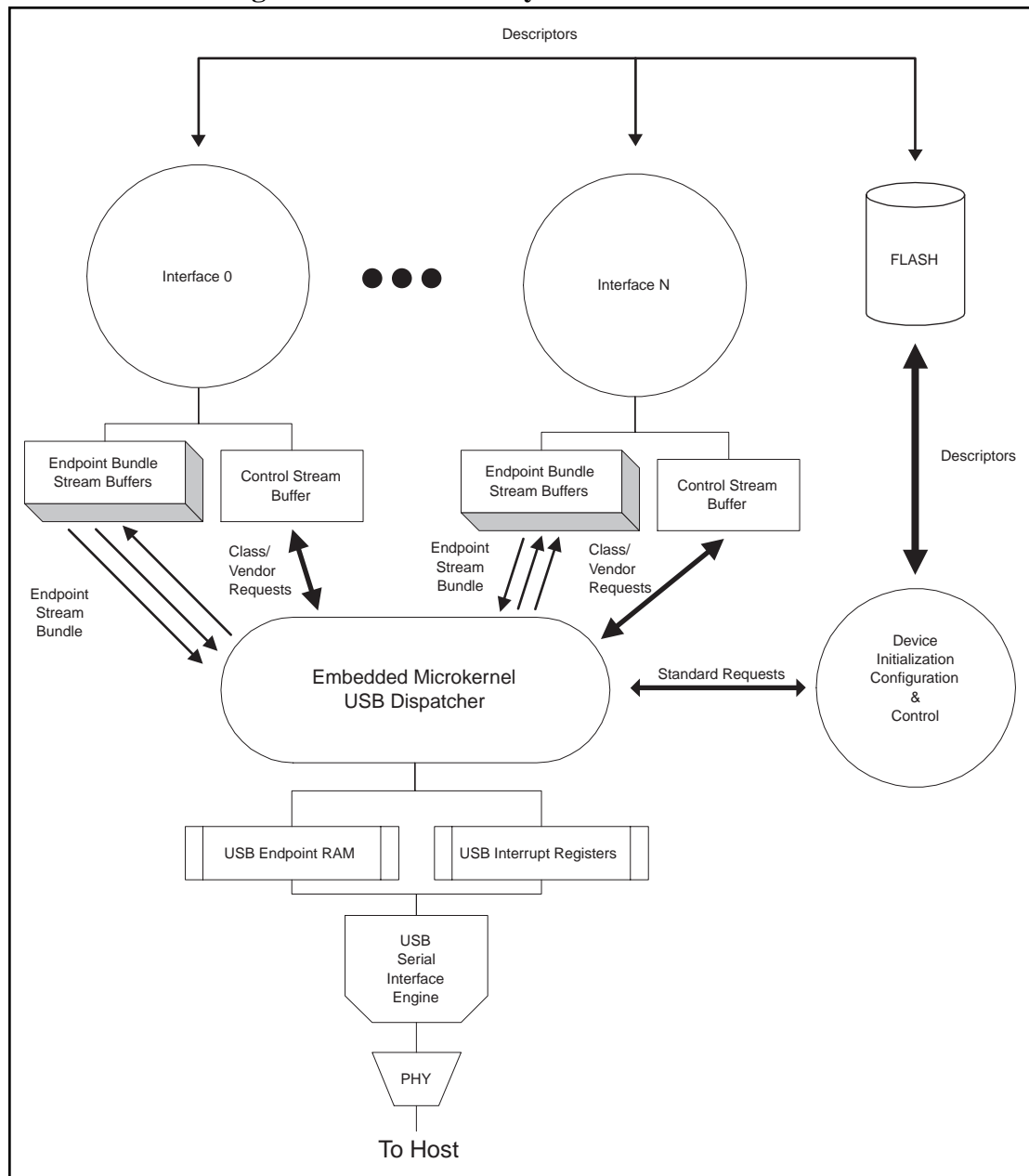
Figure 19: Embedded System Architecture

The embedded system architecture. Interaction with the hardware serial interface engine is handled by the USB dispatcher.

Figure 20: Control Endpoint Receive Channel

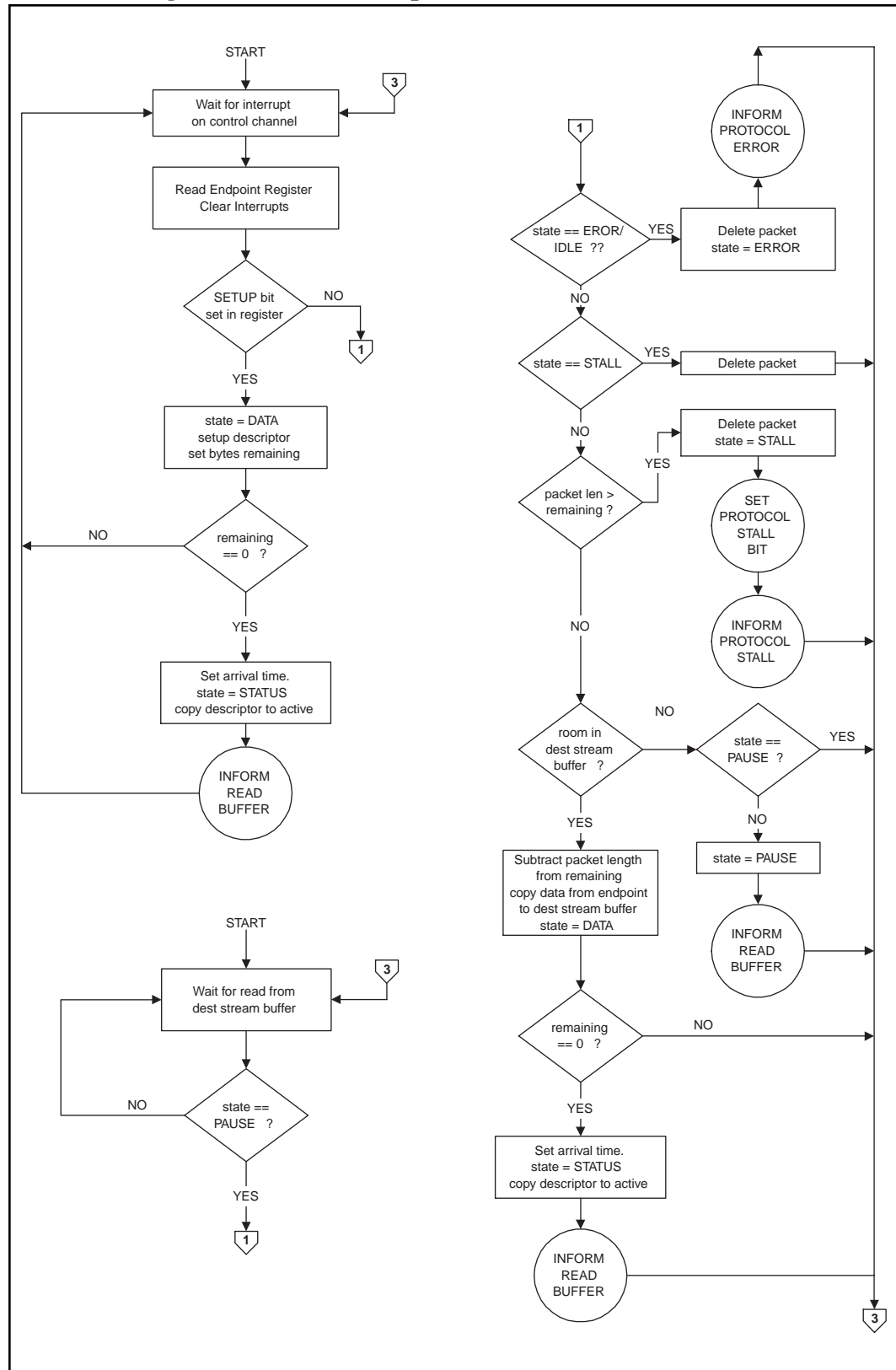

A control endpoint in receive mode. Bytes are received from the serial interface engine and transferred to the destination stream buffer. Communications external to the USB dispatcher are represented by circular states. Protocol stalls are supported as required by the USB 2.0 specification.

Figure 21: Control Endpoint Transmit Channel

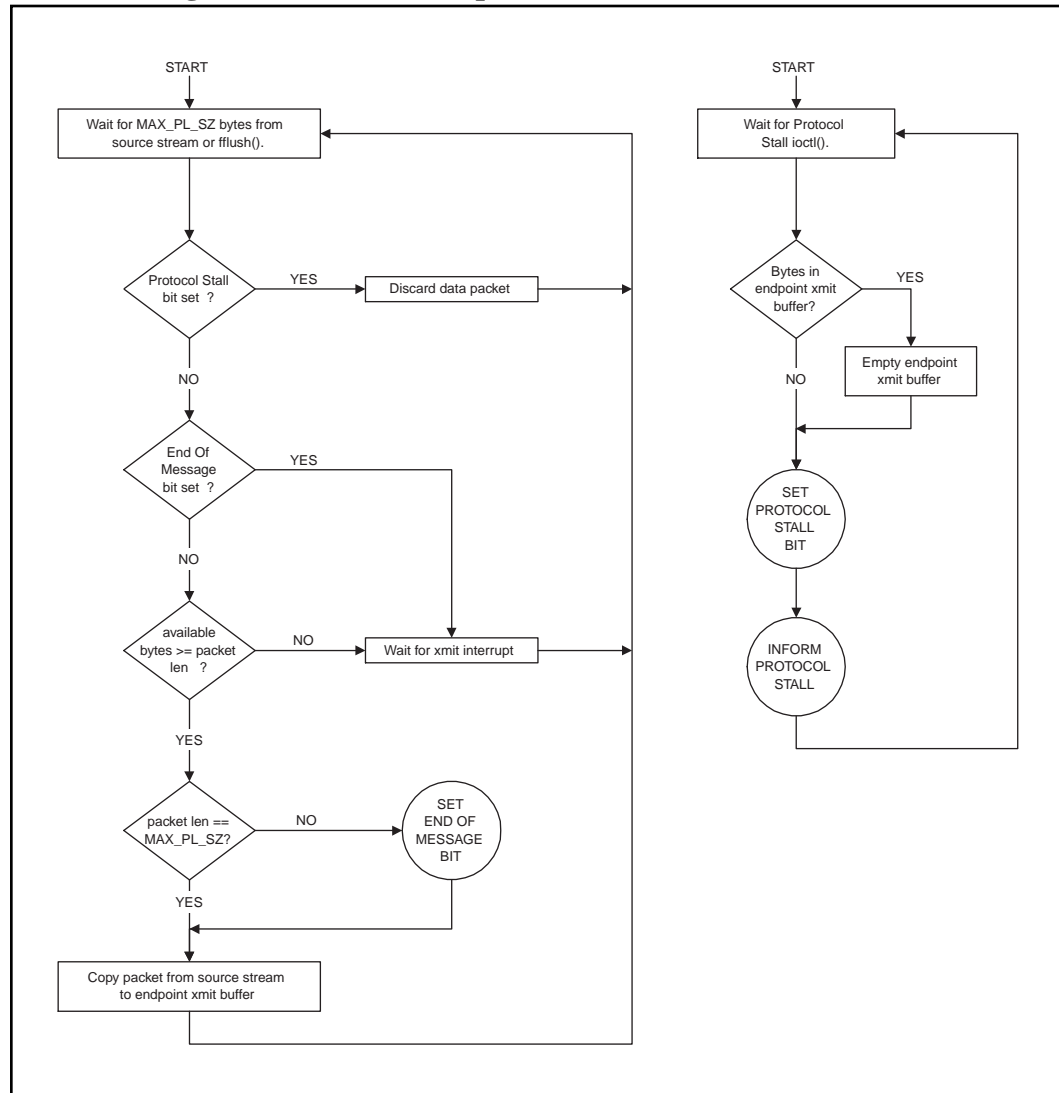

A control endpoint in transmit mode. Bytes are read from the interface stream buffer and transferred to the serial interface engine. Communications external to the USB dispatcher are represented by circular states. The transmission is considered complete upon receiving a flush from the stream buffer with a number of bytes less than MAX_PL_SIZE.

Figure 22: Isochronous Endpoint Receive Channel w/ Explicit Feedback

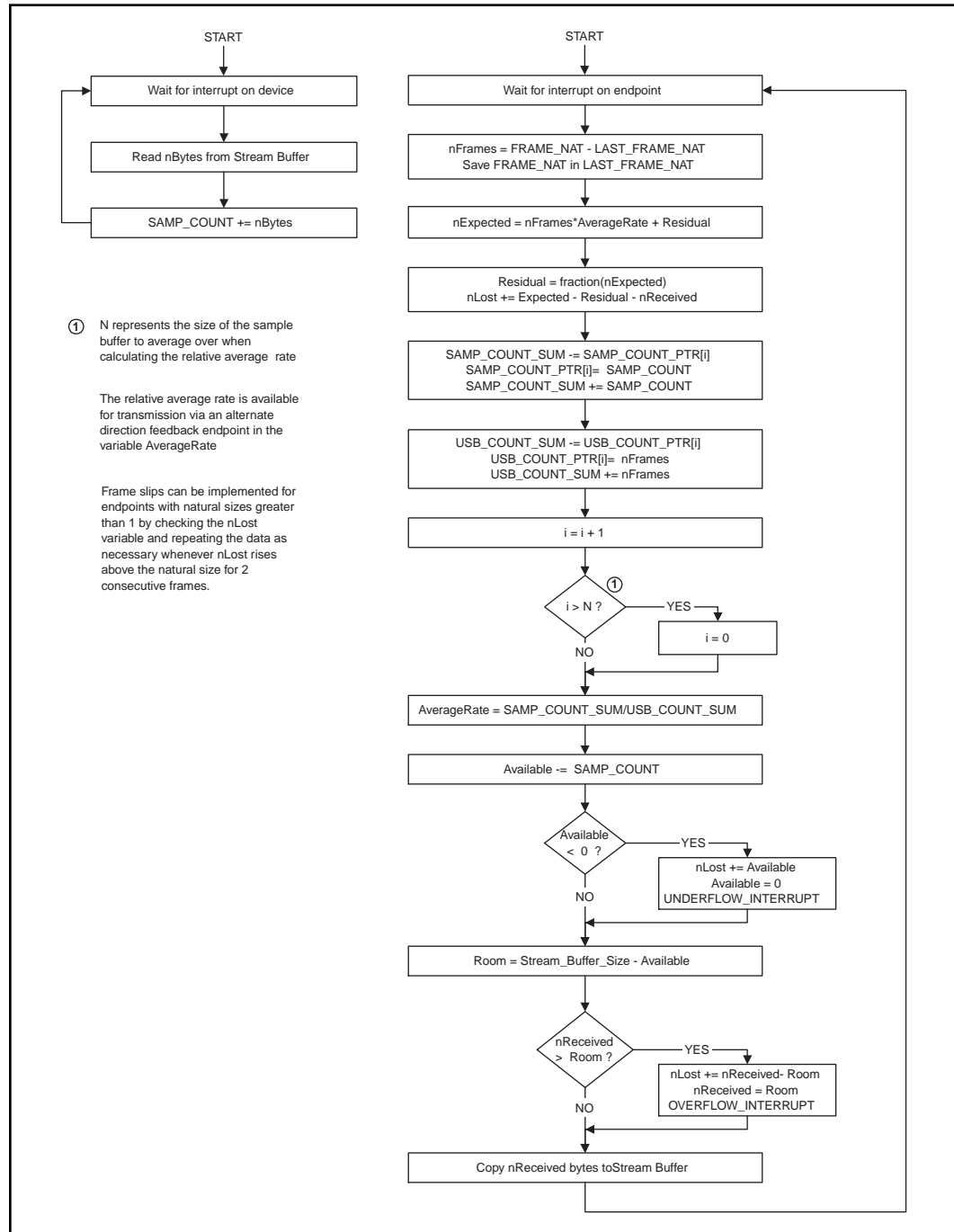

A fully adaptive isochronous endpoint in receive mode and providing explicit feedback. Bytes are read from the serial interface engine and transferred to the destination stream buffer. The flow supports an endpoint with a natural size of 1 byte, however natural sizes greater than 1 can be handled by watching the nLost variable and slipping a frame when nLost is greater than the natural size for 2 consecutive frames. (Indicating that a frame was lost in transmission.)

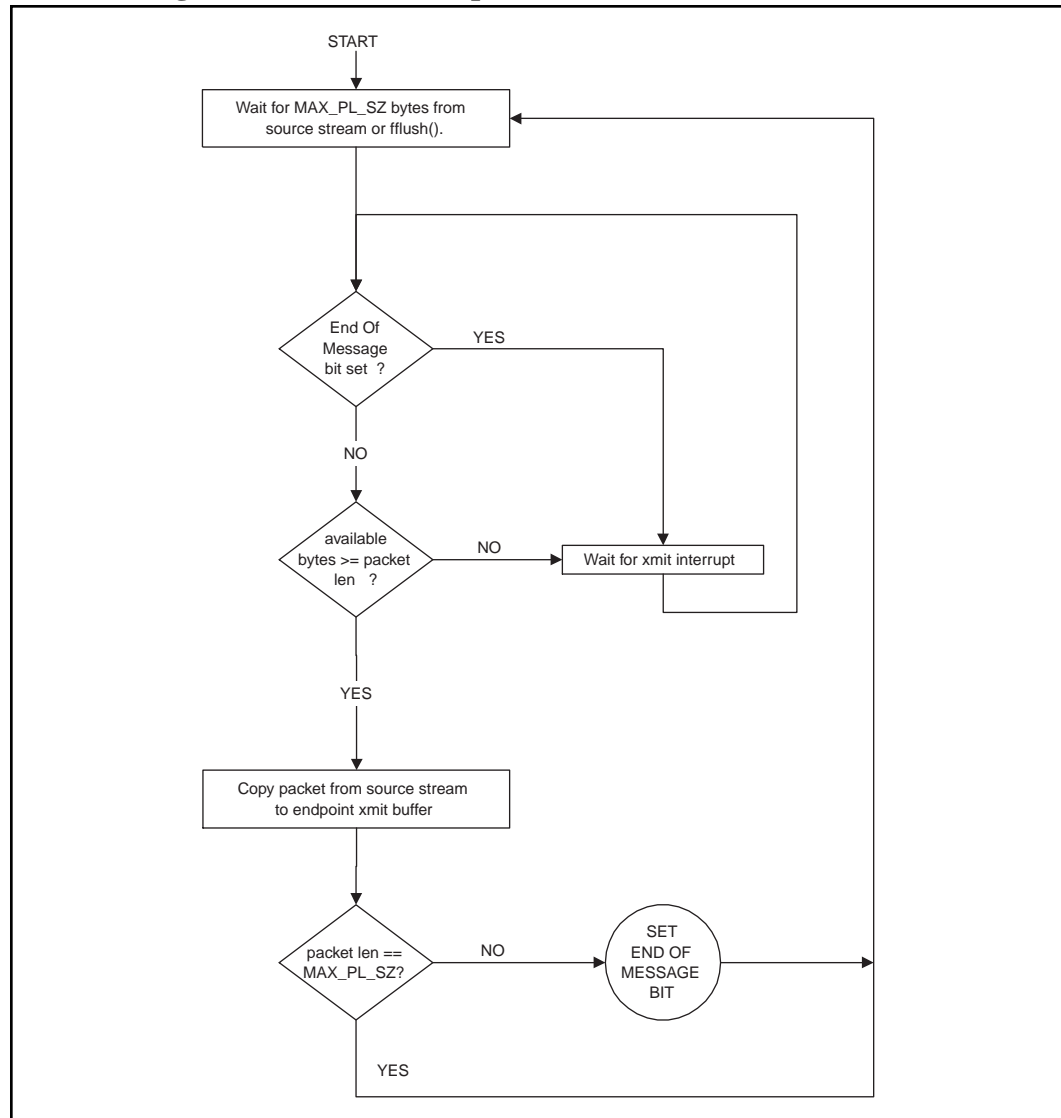
Figure 23: Bulk/Interrupt/Isochronous Transmit

A bulk, interrupt, or isochronous channel in transmit mode. Bytes are read from the interface stream buffer whenever more than MAX_PL_SIZE bytes are available or a fflush() occurs indicating a complete transmission. Bytes are copied to the serial interface engine buffers as available space permits.

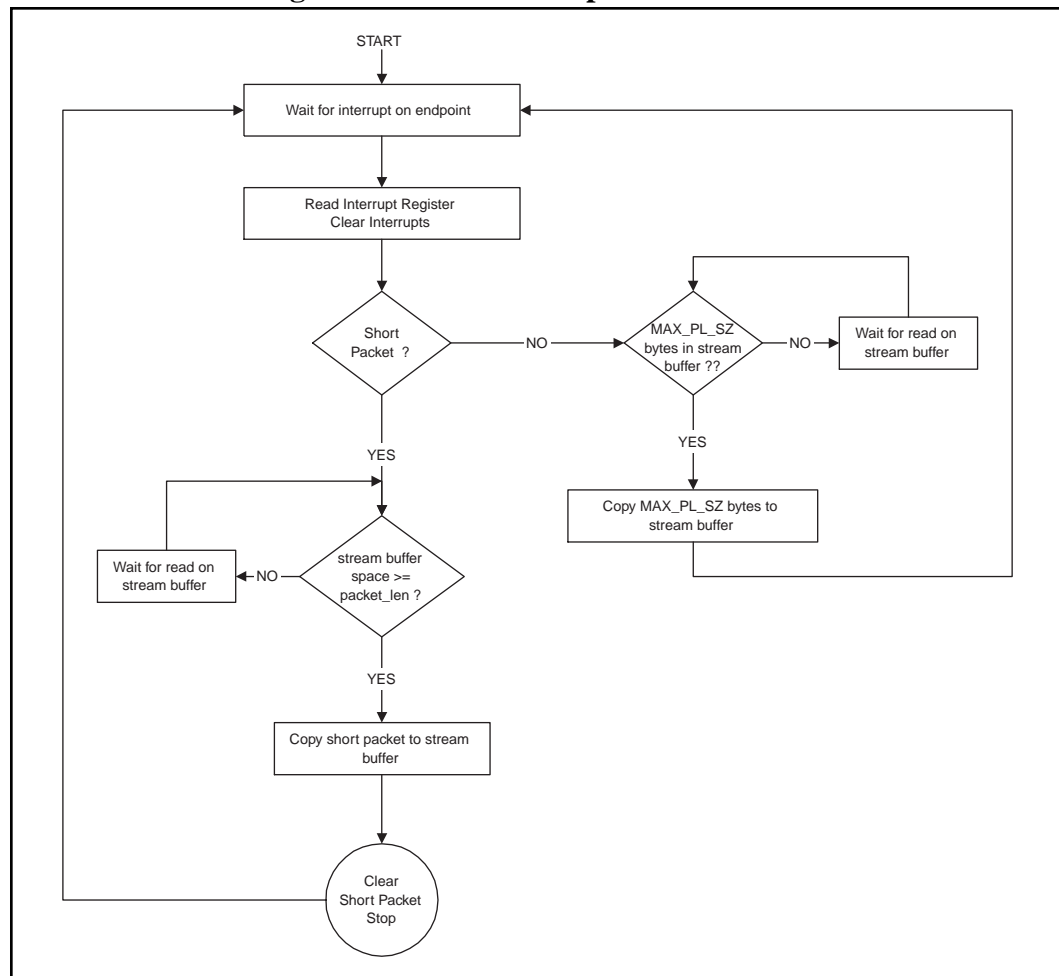
Figure 24: Bulk/Interrupt Receive

A bulk or interrupt channel in receive mode. Bytes are copied from the serial interface engine and transmitted to the destination stream buffer as space permits. A short packet signifies the end of transmission for the frame. The destination interface stream will return 0 bytes to a blocking read to indicate end of transmission.

E.1. USB Core Programmer's Guide

The Application Programming Interface (API) of a RTOS based device driver is defined by an IO System API. An RTOS typically requires the USB driver to provide functions implementing hardware and software initialization, open, close, read, write and IO Control functions. This API is called by the IO system once the driver is installed in the RTOS driver tables.

An example of this API is shown below:

- `USB_init()` – Software install and initialization, hardware configuration

- `USB_open_interface()` – Define a new interface and match it against the descriptors
- `USB_open()` – Opens an Endpoint
- `USB_close()` – Closes an Endpoint
- `USB_read()` – Performs a read operation on an Endpoint
- `USB_write()` – Performs a write operation on an Endpoint
- `USB_ioctl()` – Performs IO Control operations on an endpoint or the USB core

E.1.1. `USB_init()`

The `USB_init()` function provides the calling application with the means to install and initialize the driver while performing software and hardware configuration. The typical initialization steps required for an RTOS based USB Driver are:

- Install the USB Driver in the RTOS IO System
- Acquire the interrupts used by the USB Core
- Acquire system resources needed by the USB Core
- Acquire system resources required for each endpoint
- Initialize the USB driver data structures for the controller and each endpoint
- Initialize the USB Registers to the default values
- Start the task implementing the Standard Request Processing
- Enable the Control Endpoint 0 and associated RAM buffers
- Enable the minimum supported set of supported USB interrupts such as Suspend, Resume, Endpoint 0 ACK, and Endpoint 0 Short Packet Receive.

E.1.2. `USB_open_interface()`

The `USB_open_interface()` function provides a mechanism to establish a mapping between a task id and the standard class definition which it is implementing. The function call checks the defined descriptor database to determine the correct InterfaceID that will then be mapped to the task id. From this point on, configuration requests directed to a specific interface will be redirected to this task. A task may open more than one interface.

E.1.3. `USB_open()`

The `USB_open()` function provides the mechanism to establish an endpoint to interface mapping. The model should enforce the USB 2.0 restriction that an endpoint can only be opened by a single interface within an alternate definition. The function call should also verify that the interfaces associated with the current selected alternate definition are associated with the calling task and are configured to open this endpoint.

The typical steps performed here will be:

- Verify USB Controller State is CONFIGURED if the Endpoint is not the default Control Endpoint 0.

- Verify endpoint is not already open.
- Verify the Endpoint is valid for the current selected interface in this alternate definition
- Initialize the RAM buffers associated with this endpoint.
- Initialize the USB registers which define this endpoint as Bulk, Interrupt, Control, or Isochronous.
- Set the endpoint state to open

E.1.4. USB_close()

The USB_close() function should perform the inverse of the open functionality above, and make sure all data structures and RAM buffers associated with an endpoint are freed.

E.1.5. USB_write()

The USB_write() function allows a USB application to write data to an IN or Control endpoint.

The typical steps performed in a write call are:

- Verify endpoint number, type and direction
- Verify endpoint is in the open state
- If a control channel, acquire the semaphore to guarantee availability
- Transfer the data from the stream buffer to the USB RAM buffer for this endpoint.
- If a control channel, wait for a packet from the USB Host to complete the Control Status stage
- If a control channel, release the semaphore acquired earlier
- Return number of bytes transmitted or ERROR

E.1.6. USB_read()

The USB_read() allows a USB application to read data from an OUT or Control endpoint.

The typical steps performed in a read call are:

- Verify endpoint number, type and direction
- Verify endpoint is in the open state
- If a control channel, acquire the semaphore to guarantee availability
- Transfer the data from the USB RAM buffer for this endpoint to the stream buffer.
- If a control channel, send a packet to the USB Host to complete the Control Status stage
- If a control channel, release the semaphore acquired earlier
- Return number of bytes received or ERROR

E.1.7. USB_ioctl()

The USB_ioctl() function allows the application to read status and execute IO Control functions. These IO Control functions provide the application with the ability to control the USB interface.

Typical control mechanisms provided by this function are:

- Remote Wakeup
- Enter Suspend mode
- Exit Suspend mode (Resume)
- Reset USB Core
- Read current Start of Frame Time Stamp
- Return current Configuration, Interface, and Alternate Definition
- Get Endpoint status
- Initiate a Protocol Stall on an endpoint (control channel only)
- Enable/Disable an endpoint with the Halt bit
- Read arrival time for last message (control channel only)